



► Katherm QK, QK nano  
Trench Heating

# Katherm QK Katherm QK nano

Trench heating with  
energy-efficient EC tangential fans

► **Technical Catalogue**

**KAMPMANN**

[kampmanngroup.com/katherm-qk](http://kampmanngroup.com/katherm-qk)  
[kampmanngroup.com/katherm-qk-nano](http://kampmanngroup.com/katherm-qk-nano)  
[Kampmann.co.uk/katherm-qk](http://Kampmann.co.uk/katherm-qk)  
[Kampmann.co.uk/katherm-qk-nano](http://Kampmann.co.uk/katherm-qk-nano)

# Contents

|  |           |
|--|-----------|
| <b>Katherm QK, QK nano at a glance</b>       | <b>6</b>  |
| ‣ Product information, Katherm QK, QK nano   | 7         |
| ‣ Product data, Katherm QK, QK nano          | 8         |
| ‣ Selection guide: Overview of models        | 9         |
| <b>Katherm QK nano</b>                       | <b>10</b> |
| ‣ Katherm QK nano at a glance                | 10        |
| ‣ Grilles                                    | 12        |
| <b>02 ‣ Technical data</b>                   | <b>14</b> |
| ‣ Advice on measuring conditions             | 15        |
| ‣ 24 V electromechanical model               | 16        |
| ‣ 230 V electromechanical model or KaControl | 18        |
| <b>03 ‣ Design information</b>               | <b>20</b> |
| ‣ Information on planning and design         | 21        |
| ‣ Hydraulic installation                     | 22        |
| <b>04 ‣ Controls</b>                         | <b>23</b> |
| ‣ 24 V electromechanical model               | 23        |
| ‣ 230 V electromechanical model              | 25        |
| ‣ KaControl model                            | 27        |
| <b>05 ‣ Ordering information</b>             | <b>32</b> |
| ‣ Katherm QK nano                            | 32        |
| ‣ Accessories                                | 33        |
| <b>Katherm QK</b>                            | <b>36</b> |
| ‣ Katherm QK at a glance                     | 36        |
| ‣ Grilles                                    | 38        |
| <b>02 ‣ Technical data</b>                   | <b>40</b> |
| ‣ Advice on measuring conditions             | 41        |
| ‣ Katherm QK 190                             | 42        |
| ‣ Katherm QK 215                             | 46        |
| <b>03 ‣ Design information</b>               | <b>50</b> |
| ‣ Information on planning and design         | 51        |
| ‣ Katherm QK – Supply air modules ZL         | 52        |
| ‣ Hydraulic installation                     | 54        |
| <b>04 ‣ Controls</b>                         | <b>55</b> |
| ‣ 24 V electromechanical model               | 55        |
| ‣ 230 V electromechanical model              | 57        |
| ‣ KaControl model                            | 59        |
| <b>05 ‣ Ordering information</b>             | <b>62</b> |
| ‣ Katherm QK                                 | 62        |
| ‣ Accessories                                | 63        |



Plenty of heat from  
minimal dimensions.



Arup Office Dublin, Ireland:  
New milestone on the Grand Canal Dock.  
Expansion of a listed building to become  
an administration centre.

# 01 ▶ At a glance

---



## Katherm QK, QK nano – compact, powerful, quiet

Heaters positioned in front of windows are often unacceptable for aesthetic reasons in modern offices and other buildings with large glazed windows. At the same time, the demands of the users in terms of the aesthetics of the space are also becoming more exacting.

Katherm QK, QK nano excel in particular with low water temperatures when combined with modern heating systems thanks to their compact design, energy-saving and whisper-quiet fans with EC motors and by high-performance convectors. Narrow trench widths of only 165, 190 and 215 mm enable (almost) unrestricted use of the floor space. Fitted with the most modern EC technology, the heat outputs from every width of Katherm QK, QK nano are impressive. Measurements and CFD simulations undertaken in the Kampmann Research & Development Centre helped to develop a sound-optimised floor trench, which helps to create a pleasant interior climate.

### Function

Air is drawn in by the fan and routed through the parallel convector. The convector arranged on the window side provides for optimum screening of cold air in front of the window. The stream of warm air thus flows draught-free into the room.

### EC technology

EC motors can be operated within a significantly wider speed range due to their intelligent integrated power electronics. Low speeds generate only very low noise, partially far below the audible threshold or the usual measuring range. They means that people can spend time peacefully in living rooms, offices and hotel bedrooms. The intelligent motor management permanently detects the operating state and keeps the pre-set speed constant, regardless of the fan length and external influences.

### Fans

The cross-flow fans are matched to the application, optimised in terms of air flow and are adapted to the length of the convectors.

### Control

There are three different control schemes available for the Katherm QK and Katherm QK nano for ease of integration into individual control schemes. The space-saving 24 V versions permits direct connection to on-site building management systems. An electromechanical control option using a room thermostat or alternatively the KaControl system are both available for continuously variable control with 230 V supply voltage. KaControl represents the system solution for maximum energy efficiency, limitless integration options into building automation systems and the highest degree of user-friendly operating philosophy.

### Katherm QK 190

(Installed in screed, trench height 112 mm)

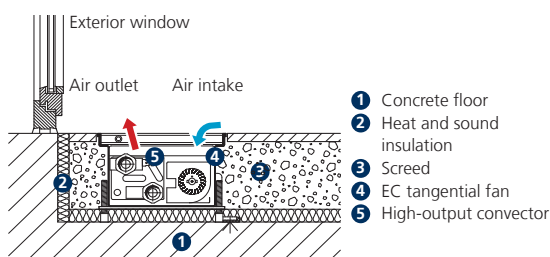

### Installation example showing QK nano

(Installed in a raised floor, trench height 70 mm)

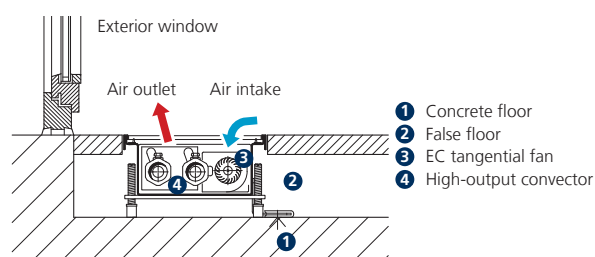

## Product data, Katherm QK, QK nano



### Product benefits

- ▶ whisper-quiet EC technology
- ▶ shallower depths and high outputs
- ▶ complete adaptation to building contours

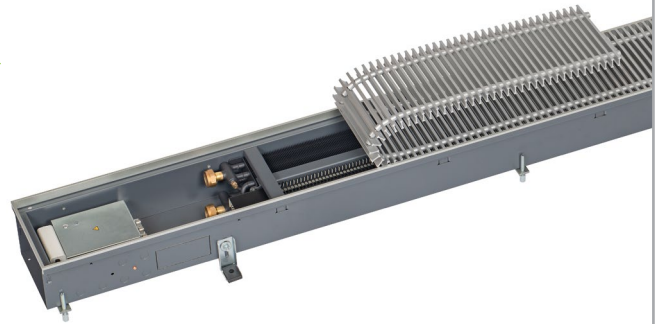

### Features

#### Standard range

##### Katherm QK nano:

1 trench width each with 5 trench lengths, 1 trench height, 3 control options.

##### Katherm QK:

2 trench widths, 12 trench lengths, 1 trench height, 3 control options.

Notwithstanding the standard range (NP), the products can also be individually manufactured in line with the non-standard program (MP).

- Convection** ▶ EC tangential fan
- Heating** ▶ LPHW
- Cooling** ▶ ---
- Ventilation** ▶ ---
- KaControl System** ▶ integrated
- ▶ 2-pipe

#### Grille finishes

##### Katherm QK nano:

- ▶ FineLine Q (orthogonal grille)
- ▶ FineLine L (linear grille)
- ▶ bar spacing 4.8 mm

##### Katherm QK:

- ▶ Optiline roll-up grilles
- ▶ Optiline lines grilles
- ▶ aluminium brass, bar spacing 12 mm (9 mm optional); stainless steel, bar spacing 10.5 mm

### Performance data

#### Heat output<sup>1)</sup> [W]

- ▶ 248-6025

#### Sound pressure level<sup>2)</sup> [dB(A)]

- ▶ 20–41

#### Sound power level [dB(A)]

- ▶ 28–49

### Applications

All areas of buildings in which effective heating and cold air screening is required. Effective, energy-saving heating can be provided by Katherm QK in conjunction with modern heating systems.



Hotels/  
motels



Sales rooms  
and  
showrooms



Office and  
meeting  
rooms



Homes and  
conservatories



Restaurants  
and cafés

<sup>1)</sup> At LPHW 75 / 65°C,  $t_{L1} = 20^\circ\text{C}$ , with fan-assisted convection

<sup>2)</sup> The sound pressure levels were calculated with an assumed room insulation of 8 dB(A). This corresponds to a distance of 2 m, a room volume of 100 m<sup>3</sup> and a reverberation time of 0.5 s (in accordance with VDI 2081), at 60% fan speed.



# Selection guide: overview of models

| Katherm        | Control option   | Trench width | Trench height | Trench length | Grille  | Heat output <sup>1)</sup> | Sound pressure level <sup>2)</sup> | Sound power level     | Further information |
|----------------|--|--------------|---------------|---------------|---|---------------------------|------------------------------------|-----------------------|---------------------|
|                |  | [mm]         | [mm]          | [mm]          |   | [W]                       | [dB(A)]                            | [dB(A)]               |                     |
| <b>QK nano</b> | KaControl<br>230 V<br>electromechanical                              | 165          | 70            | 1100-2700     | FineLine Q<br>(orthogonal grille)   | 248-3524                  | <20 <sup>3)</sup> -41              | <28 <sup>3)</sup> -49 | ► Page 18           |
| <b>QK nano</b> | 24 V<br>electromechanical  | 165          | 70            | 900-2600      | FineLine L<br>(linear grille)<br>BS 4.8 mm  | 248-3524                  | <20 <sup>3)</sup> -41              | <28 <sup>3)</sup> -49 | ► Page 16           |
| <b>QK 190</b>  | KaControl<br>230 V<br>electromechanical<br>24 V<br>electromechanical | 190          | 112           | 1000-3200     | Roll-up grille<br>Linear grille<br>BS 12 mm <sup>4)</sup> ,<br>free area approx.<br>70% | 437-5781                  | <20 <sup>3)</sup> -41              | <28 <sup>3)</sup> -49 | ► Page 42           |
| <b>QK 215</b>  | KaControl<br>230 V<br>electromechanical<br>24 V<br>electromechanical | 215          | 112           | 1000-3200     |   | 522-6025                  | <20 <sup>3)</sup> -41              | <28 <sup>3)</sup> -49 | ► Page 46           |

## Sectional views

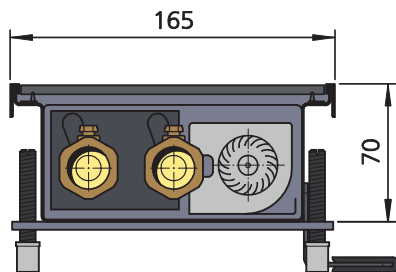

Katherm QK nano

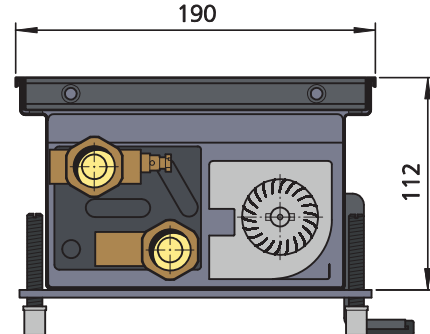

Katherm QK 190

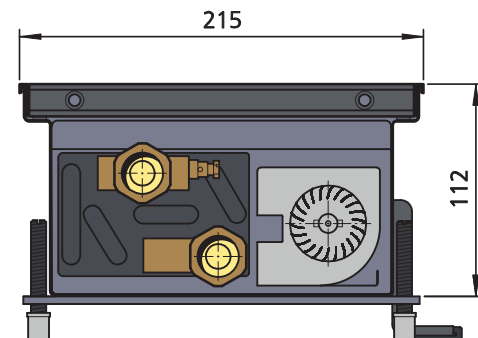

Katherm QK 215

<sup>1)</sup> At LPHW 75 / 65,  $t_{11} = 20^{\circ}\text{C}$ , with fan-assisted convection. The heat outputs were measured and determined in accordance with DIN EN 16430 "Fan-assisted radiators, convectors and trench heaters" Part 1: "Technical specifications and requirements" and Part 2: "Test procedures and evaluation of heat outputs".  
<sup>2)</sup> The sound pressure levels were calculated with an assumed room insulation of 8 dB(A). This corresponds to a clearance of 2 m, a room volume of 100 m<sup>3</sup> and a reverberation time of 0.5 s (in accordance with VDI 2081).  
<sup>3)</sup> Sound pressure level < 20 dB (A) and sound power level < 28 dB (A) outside the usual measuring and audible range.  
<sup>4)</sup> Heat outputs with BS 9 mm (aluminium anodised, brass) and BS 10.5 mm (stainless steel); free area approx. 65 % can be obtained from the calculation program.

# Katherm QK nano

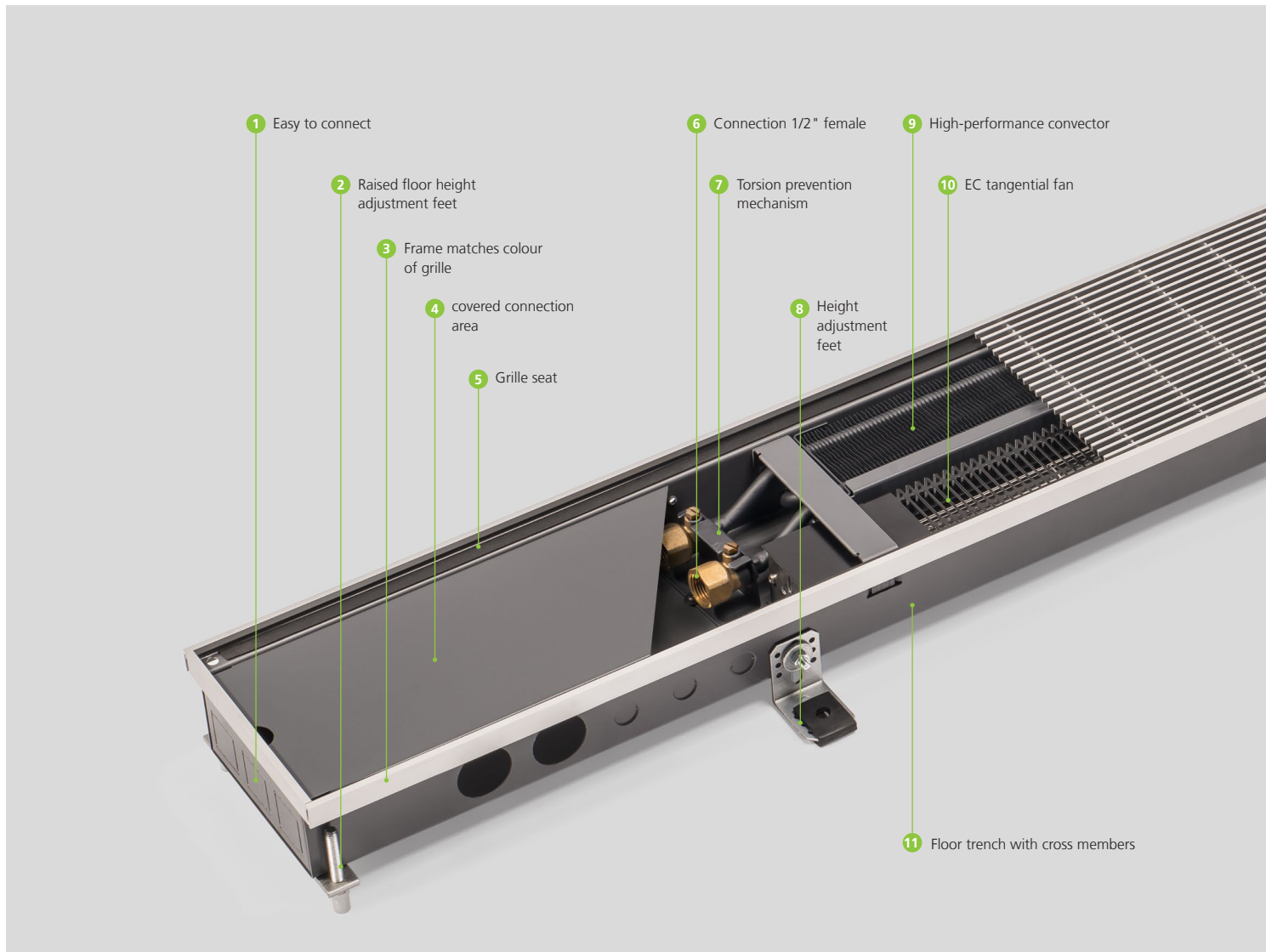

## Features

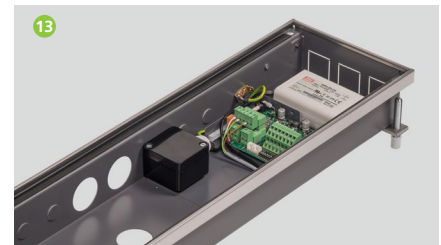
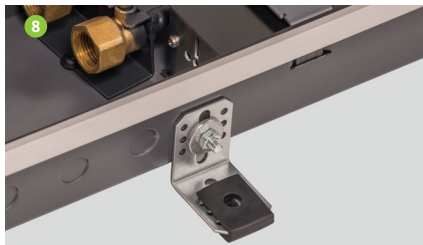
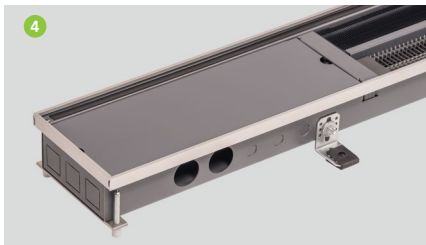

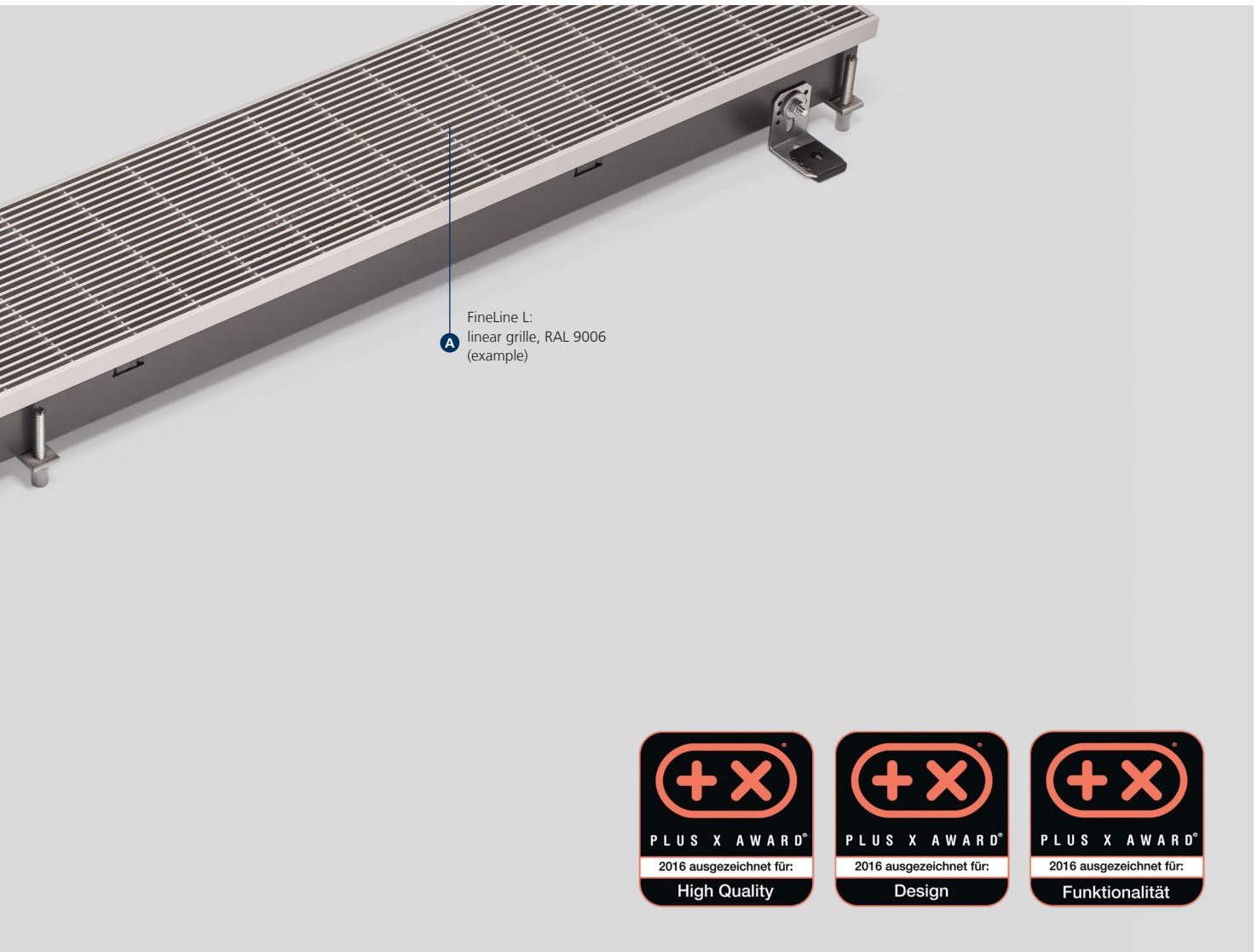

**A** FineLine L:  
linear grille, RAL 9006  
(example)



- 1 Easy to connect**
  - ▶ removable end panel for ease of connection of trenches
- 2 Load-bearing height adjustment feet**
  - ▶ for the secure mounting of the trench
  - ▶ with plastic cap for acoustic decoupling
- 3 Frame matches colour of grille**
- 4 Connection area**
  - ▶ for valves and electrical components
  - ▶ with cover for visual protection and to protect against dirt
- 5 Grille seat**
  - ▶ for impact sound insulation and acoustic decoupling
- 6 Connection 1/2" female**
  - ▶ for fast connection
  - ▶ space-saving
- 7 Torsion prevention mechanism**
  - ▶ prevents damage to the convector when installing the valves
- 8 Height adjustment feet**
  - ▶ for the simple fixing of the floor trench
  - ▶ with rubber pad for sound insulation
- 9 High-performance convector**
  - ▶ proven combination of copper/aluminium
  - ▶ optimised for air flow and heat dissipation
  - ▶ graphite-grey coated
- 10 EC tangential fan**
  - ▶ for even airflow through the convector,
  - ▶ robust motor design
  - ▶ continuously variable speed control via an external 0 – 10V signal
- 11 Floor trench**
  - ▶ galvanised sheet steel
  - ▶ graphite-grey coated on both sides
  - ▶ with cross bracing to reinforce the floor trench
- 12 24 V electromechanical electrical connection**
- 13 Electrical connection, electro-mechanical 230 V/KaControl**
  - ▶ includes 230/24 V power unit, PCB and junction box
- A FineLine L: linear grille, RAL 9006 (example)**
  - ▶ rigid grille, airflow-optimised triangular profiles
  - ▶ available as the FineLine Q (orthogonal grille) or FineLine L (linear grille)
  - ▶ available in powder coated steel or natural stainless steel
  - ▶ free area approx. 70%

## Matching grilles

### FineLine Q

**Powder coated steel**

RAL 9006 white aluminium

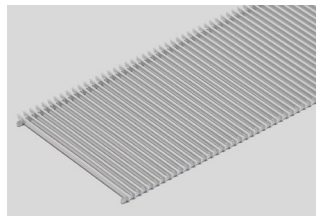

**Powder coated steel**

RAL 9007 grey aluminium

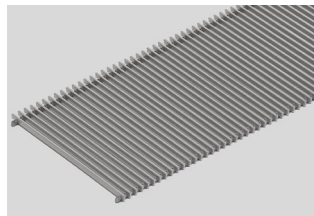

**Powder coated steel**

RAL 9005 black

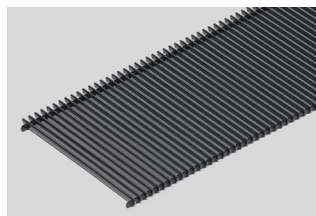

**Powder coated steel**

DB 703 basalt grey

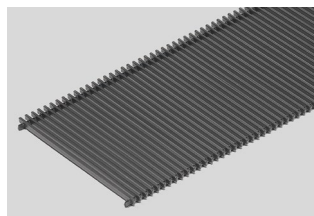

**Stainless steel**

Natural



## FineLine L

**Powder coated steel**  
RAL 9006 white aluminium

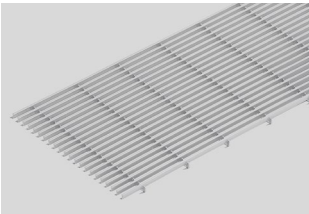

**Powder coated steel**  
RAL 9007 grey aluminium

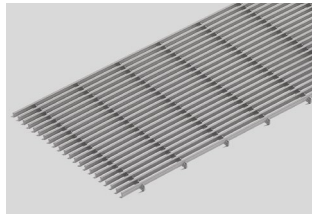

**Powder coated steel**  
RAL 9005 black

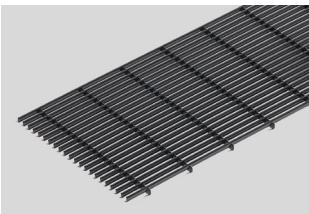

**Powder coated steel**  
DB 703 basalt grey

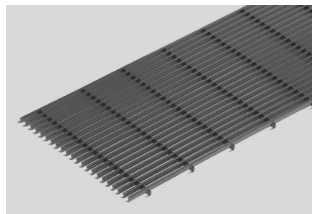

**Stainless steel**  
Natural

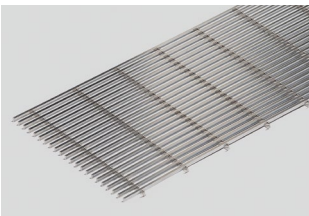

► For more grilles, please refer to  
[Kampmann.co.uk/grilles](http://Kampmann.co.uk/grilles)

The above grilles are shown using a four-colour printing process and thus do not represent an exact reproduction of the original colour.

## Digram of FineLine profiles

### Airflow-optimised triangular profile

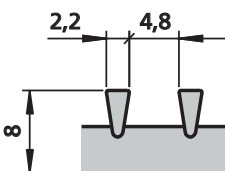

There can be slight deviations in colour between the grille and frame trim.

# 02 ▶ Technical data

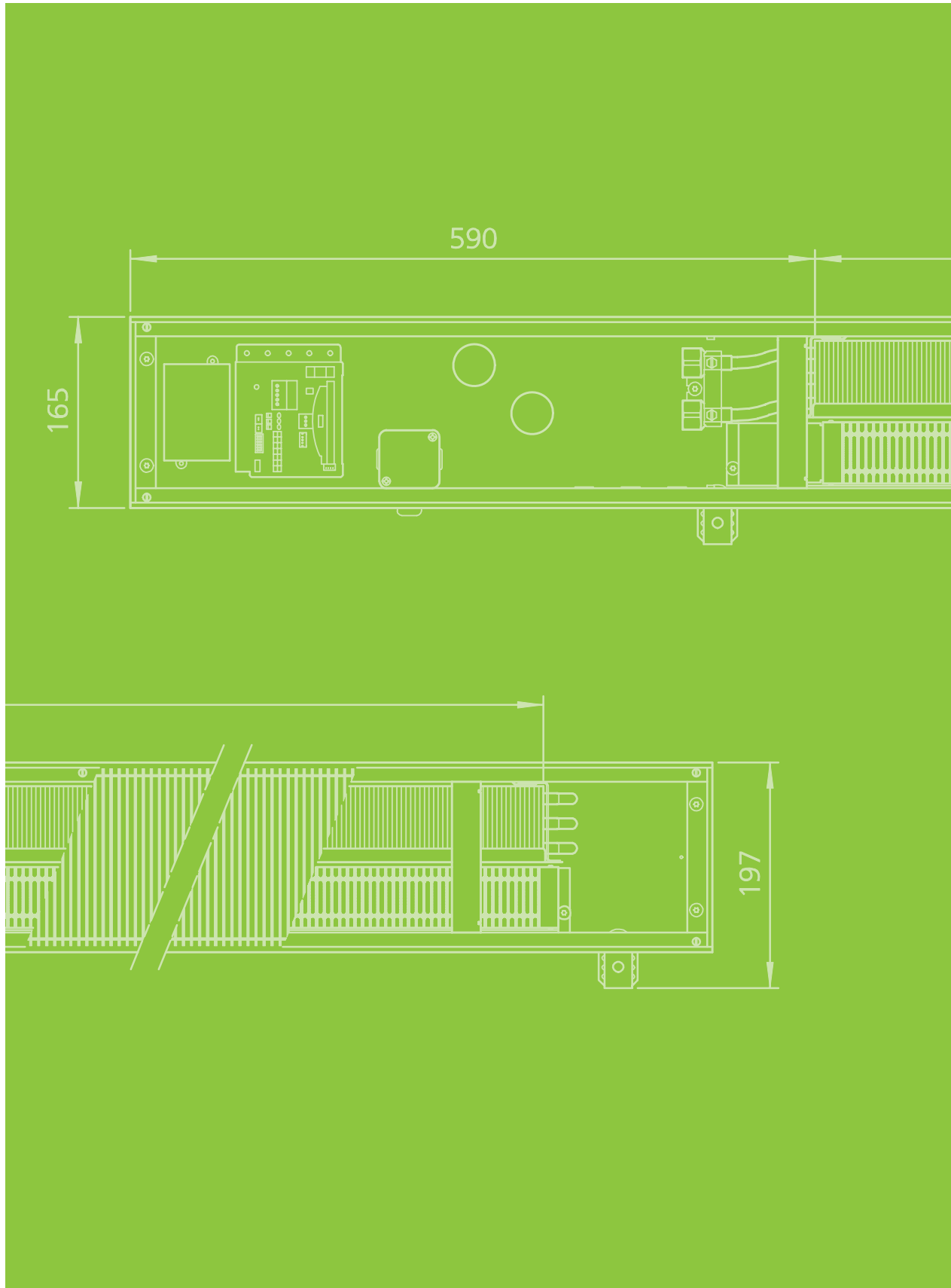

## Advice on measuring conditions

### Heat outputs

The heat outputs have been tested in accordance with DIN EN 16430 ( "Fan assisted heaters, convectors, trench convectors").

The standard regulates the performance measurements specifically of trench convectors based on DIN EN 442. Two parts of DIN EN 16430 describe the measurement of the heat outputs.

Part 1 "Technical specifications and requirements"  
Part 2 "Test method and evaluation of heat output"

The specific requirements for trench heating are taken into account in DIN EN 16430. The reference air temperature is measured in the centre of the test chamber (2 metres from the external wall) at a height of 0.75 metres. The surface temperature of the façade is 16 °C. Experience has shown that the practical distance of the trench convector from the façade is 50 mm.

### Acoustics

Katherm QK nano are very often used in acoustically sensitive areas. Accordingly, Katherm QK nano have been optimised in terms of noise levels. The sound power level is measured according to DIN EN ISO 3744 in a semi-low reflective sound measuring chamber.

### Air flow simulation

CFD simulations were used to support the development of the Katherm QK nano, enabling the air flows in the trench to be visualised and optimised.



Air flow laboratory

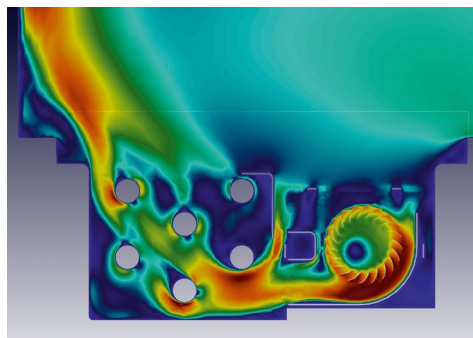

# Katherm QK nano, 24 V electromechanical model

Technical drawings (all dimensions in mm)

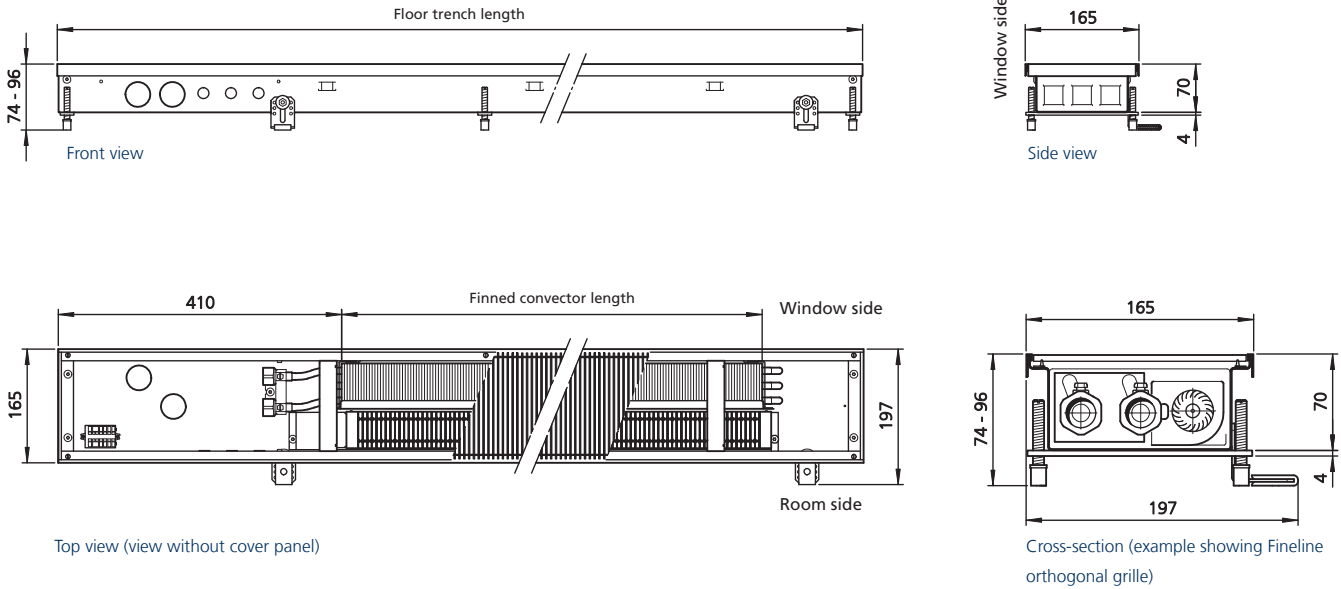

| Trench length | Finned convector length |
|---------------|-------------------------|
| [mm]          | [mm]                    |
| 900           | 435                     |
| 1400          | 870                     |
| 1800          | 1305                    |
| 2100          | 1640                    |
| 2600          | 1985                    |

## Specifications

**Connections, female thread:**  
1/2", same end,  
connections on left

Make use of our online calculation programs to calculate your heat outputs and flow rates with a couple of clicks!

- ▶ [Kampmann.co.uk/katherm-qk-nano/calculation](http://Kampmann.co.uk/katherm-qk-nano/calculation)
- ▶ [Kampmann.eu/katherm-qk-nano/calculation](http://Kampmann.eu/katherm-qk-nano/calculation)

## Water pressure drop: heating curve

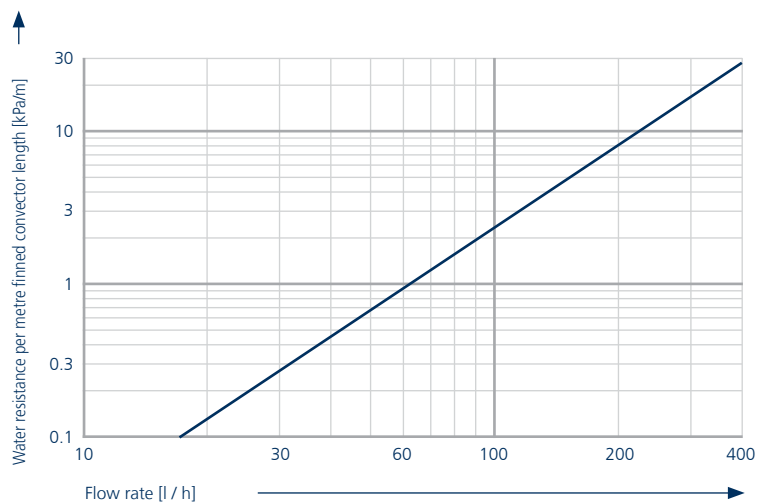



## Outputs



| Fan stage                    | at speed setting | Heat outputs <sup>1)</sup> |                    | Power consumption <sup>2)</sup> | Current consumption | Air volume          | Sound pressure level <sup>3)</sup> | Sound power level  |
|------------------------------|------------------|----------------------------|--------------------|---------------------------------|---------------------|---------------------|------------------------------------|--------------------|
|                              |                  | at LPHW 75 / 65 °C         | at LPHW 82 / 71 °C |                                 |                     |                     |                                    |                    |
|                              | [%]              | Q <sub>N</sub> [W]         | Q [W]              | P [W]                           | I [mA]              | [m <sup>3</sup> /h] | [dB(A)]                            | [dB(A)]            |
| <b>Trench length 900 mm</b>  |                  |                            |                    |                                 |                     |                     |                                    |                    |
| <b>Boost stage</b>           | 100              | 772                        | 874                | 5.0                             | 208                 | 75                  | 34                                 | 42                 |
| <b>Design levels</b>         | 80               | 663                        | 748                | 3.0                             | 109                 | 60                  | 30                                 | 38                 |
|                              | 60               | 539                        | 607                | 2.0                             | 63                  | 50                  | 22                                 | 30                 |
|                              | 40               | 407                        | 458                | 1.0                             | 33                  | 35                  | < 20 <sup>4)</sup>                 | < 28 <sup>4)</sup> |
| <b>Minimum stage</b>         | 20               | 248                        | 295                | 1.0                             | 17                  | 25                  | < 20 <sup>4)</sup>                 | < 28 <sup>4)</sup> |
| <b>Natural convection</b>    |                  | 52                         | 61                 | ---                             | ---                 | ---                 | ---                                | ---                |
| <b>Trench length 1400 mm</b> |                  |                            |                    |                                 |                     |                     |                                    |                    |
| <b>Boost stage</b>           | 100              | 1545                       | 1748               | 6.0                             | 227                 | 155                 | 37                                 | 45                 |
| <b>Design levels</b>         | 80               | 1326                       | 1496               | 3.0                             | 125                 | 120                 | 33                                 | 41                 |
|                              | 60               | 1078                       | 1214               | 2.0                             | 75                  | 95                  | 25                                 | 33                 |
|                              | 40               | 813                        | 917                | 1.0                             | 41                  | 70                  | < 20 <sup>4)</sup>                 | < 28 <sup>4)</sup> |
| <b>Minimum stage</b>         | 20               | 496                        | 590                | 1.0                             | 23                  | 50                  | < 20 <sup>4)</sup>                 | < 28 <sup>4)</sup> |
| <b>Natural convection</b>    |                  | 104                        | 121                | ---                             | ---                 | ---                 | ---                                | ---                |
| <b>Trench length 1800 mm</b> |                  |                            |                    |                                 |                     |                     |                                    |                    |
| <b>Boost stage</b>           | 100              | 2317                       | 2621               | 7.0                             | 258                 | 230                 | 39                                 | 47                 |
| <b>Design levels</b>         | 80               | 1989                       | 2244               | 4.0                             | 147                 | 180                 | 35                                 | 43                 |
|                              | 60               | 1618                       | 1821               | 3.0                             | 89                  | 145                 | 27                                 | 35                 |
|                              | 40               | 1220                       | 1375               | 2.0                             | 51                  | 105                 | < 20 <sup>4)</sup>                 | < 28 <sup>4)</sup> |
| <b>Minimum stage</b>         | 20               | 744                        | 885                | 1.0                             | 30                  | 75                  | < 20 <sup>4)</sup>                 | < 28 <sup>4)</sup> |
| <b>Natural convection</b>    |                  | 156                        | 182                | ---                             | ---                 | ---                 | ---                                | ---                |
| <b>Trench length 2100 mm</b> |                  |                            |                    |                                 |                     |                     |                                    |                    |
| <b>Boost stage</b>           | 100              | 2912                       | 3294               | 8.0                             | 333                 | 290                 | 40                                 | 48                 |
| <b>Design levels</b>         | 80               | 2499                       | 2820               | 6.0                             | 212                 | 225                 | 36                                 | 44                 |
|                              | 60               | 2033                       | 2288               | 3.0                             | 121                 | 180                 | 28                                 | 36                 |
|                              | 40               | 1533                       | 1728               | 2.0                             | 68                  | 130                 | 20                                 | 28                 |
| <b>Minimum stage</b>         | 20               | 935                        | 1112               | 1.0                             | 41                  | 95                  | < 20 <sup>4)</sup>                 | < 28 <sup>4)</sup> |
| <b>Natural convection</b>    |                  | 196                        | 229                | ---                             | ---                 | ---                 | ---                                | ---                |
| <b>Trench length 2600 mm</b> |                  |                            |                    |                                 |                     |                     |                                    |                    |
| <b>Boost stage</b>           | 100              | 3524                       | 3987               | 13.0                            | 477                 | 345                 | 41                                 | 49                 |
| <b>Design levels</b>         | 80               | 3025                       | 3414               | 7.0                             | 265                 | 270                 | 37                                 | 45                 |
|                              | 60               | 2461                       | 2770               | 5.0                             | 161                 | 220                 | 29                                 | 37                 |
|                              | 40               | 1856                       | 2092               | 3.0                             | 89                  | 160                 | 21                                 | 29                 |
| <b>Minimum stage</b>         | 20               | 1132                       | 1346               | 2.0                             | 51                  | 115                 | < 20 <sup>4)</sup>                 | < 28 <sup>4)</sup> |
| <b>Natural convection</b>    |                  | 238                        | 277                | ---                             | ---                 | ---                 | ---                                | ---                |

Q<sub>N</sub> [W] = Standard heat output

Q [W] = Heat output

<sup>1)</sup> At room temperature t<sub>L</sub> = 20 °C

<sup>2)</sup> Add an additional power consumption of 1 W per valve drive type 146906.

<sup>3)</sup> The sound pressure levels were calculated with an assumed room insulation of 8 dB(A). This corresponds to a clearance of 2 m, a room volume of 100 m<sup>3</sup> and a reverberation time of 0.5 s (according to VDI 2081).

<sup>4)</sup> Sound pressure level < 20 dB (A) and sound power level < 28 dB (A) outside the usual measuring and audible range.

# Katherm QK nano, 230 V electromechanical model or KaControl

Technical drawings (all dimensions in mm)

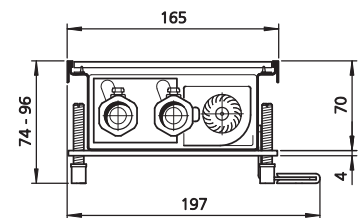
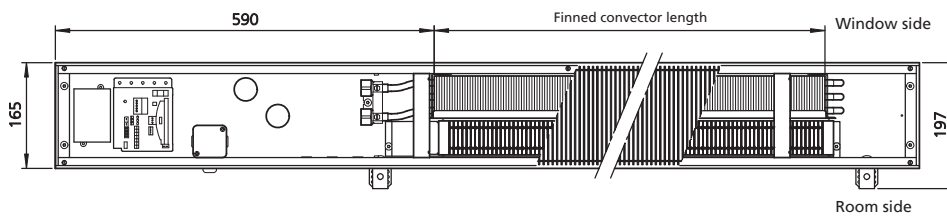
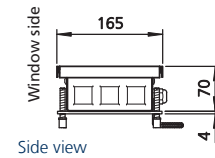
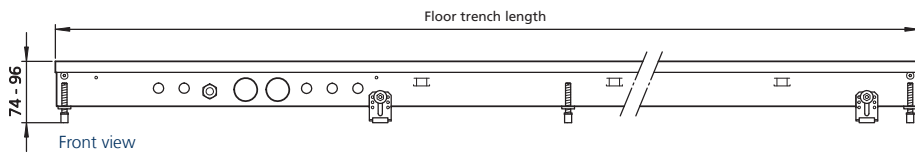

Top view (view without cover panel)

Cross-section (example showing Fineline orthogonal grille)

| Trench convector length A | Finned convector length B |
|---------------------------|---------------------------|
| [mm]                      | [mm]                      |
| 1100                      | 435                       |
| 1600                      | 870                       |
| 2000                      | 1305                      |
| 2300                      | 1640                      |
| 2700                      | 1985                      |

## Specifications

**Connections, female thread:**  
1/2", same end,  
connections on left

Make use of our online calculation programs to calculate your heat outputs and flow rates with a couple of clicks!

- ▶ [Kampmann.co.uk/katherm-qk-nano/calculation](http://Kampmann.co.uk/katherm-qk-nano/calculation)
- ▶ [Kampmann.eu/katherm-qk-nano/calculation](http://Kampmann.eu/katherm-qk-nano/calculation)

## Water pressure drop: heating curve

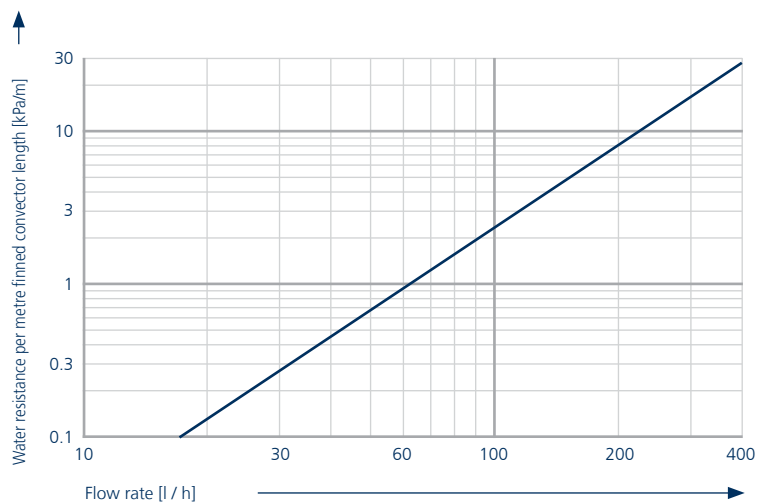

## Outputs



| Fan stage                    | at speed setting | Heat outputs <sup>1)</sup> |                    | Power consumption <sup>2)</sup> | Current consumption | Air volume          | Sound pressure level <sup>3)</sup> | Sound power level  |
|------------------------------|------------------|----------------------------|--------------------|---------------------------------|---------------------|---------------------|------------------------------------|--------------------|
|                              |                  | at LPHW 75 / 65 °C         | at LPHW 82 / 71 °C |                                 |                     |                     |                                    |                    |
|                              | [%]              | Q <sub>N</sub> [W]         | Q [W]              | P [W]                           | I [mA]              | [m <sup>3</sup> /h] | [dB(A)]                            | [dB(A)]            |
| <b>Trench length 1100 mm</b> |                  |                            |                    |                                 |                     |                     |                                    |                    |
| <b>Boost stage</b>           | 100              | 772                        | 874                | 6.0                             | 249                 | 75                  | 34                                 | 42                 |
| <b>Design levels</b>         | 80               | 663                        | 748                | 4.0                             | 151                 | 60                  | 30                                 | 38                 |
|                              | 60               | 539                        | 607                | 3.0                             | 105                 | 50                  | 22                                 | 30                 |
|                              | 40               | 407                        | 458                | 2.0                             | 74                  | 35                  | < 20 <sup>4)</sup>                 | < 28 <sup>4)</sup> |
| <b>Minimum stage</b>         | 20               | 248                        | 295                | 2.0                             | 59                  | 25                  | < 20 <sup>4)</sup>                 | < 28 <sup>4)</sup> |
| <b>Natural convection</b>    |                  | 52                         | 61                 | ---                             | ---                 | ---                 | ---                                | ---                |
| <b>Trench length 1600 mm</b> |                  |                            |                    |                                 |                     |                     |                                    |                    |
| <b>Boost stage</b>           | 100              | 1545                       | 1748               | 7.0                             | 269                 | 155                 | 37                                 | 45                 |
| <b>Design levels</b>         | 80               | 1326                       | 1496               | 4.0                             | 166                 | 120                 | 33                                 | 41                 |
|                              | 60               | 1078                       | 1214               | 3.0                             | 117                 | 95                  | 25                                 | 33                 |
|                              | 40               | 813                        | 917                | 2.0                             | 83                  | 70                  | < 20 <sup>4)</sup>                 | < 28 <sup>4)</sup> |
| <b>Minimum stage</b>         | 20               | 496                        | 590                | 2.0                             | 65                  | 50                  | < 20 <sup>4)</sup>                 | < 28 <sup>4)</sup> |
| <b>Natural convection</b>    |                  | 104                        | 121                | ---                             | ---                 | ---                 | ---                                | ---                |
| <b>Trench length 2000 mm</b> |                  |                            |                    |                                 |                     |                     |                                    |                    |
| <b>Boost stage</b>           | 100              | 2317                       | 2621               | 8.0                             | 299                 | 230                 | 39                                 | 47                 |
| <b>Design levels</b>         | 80               | 1989                       | 2244               | 5.0                             | 188                 | 180                 | 35                                 | 43                 |
|                              | 60               | 1618                       | 1821               | 4.0                             | 131                 | 145                 | 27                                 | 35                 |
|                              | 40               | 1220                       | 1375               | 3.0                             | 93                  | 105                 | < 20 <sup>4)</sup>                 | < 28 <sup>4)</sup> |
| <b>Minimum stage</b>         | 20               | 744                        | 885                | 2.0                             | 71                  | 75                  | < 20 <sup>4)</sup>                 | < 28 <sup>4)</sup> |
| <b>Natural convection</b>    |                  | 156                        | 182                | ---                             | ---                 | ---                 | ---                                | ---                |
| <b>Trench length 2300 mm</b> |                  |                            |                    |                                 |                     |                     |                                    |                    |
| <b>Boost stage</b>           | 100              | 2912                       | 3294               | 9.0                             | 375                 | 290                 | 40                                 | 48                 |
| <b>Design levels</b>         | 80               | 2499                       | 2820               | 7.0                             | 253                 | 225                 | 36                                 | 44                 |
|                              | 60               | 2033                       | 2288               | 4.0                             | 163                 | 180                 | 28                                 | 36                 |
|                              | 40               | 1533                       | 1728               | 3.0                             | 110                 | 130                 | 20                                 | 28                 |
| <b>Minimum stage</b>         | 20               | 935                        | 1112               | 2.0                             | 83                  | 95                  | < 20 <sup>4)</sup>                 | < 28 <sup>4)</sup> |
| <b>Natural convection</b>    |                  | 196                        | 229                | ---                             | ---                 | ---                 | ---                                | ---                |
| <b>Trench length 2700 mm</b> |                  |                            |                    |                                 |                     |                     |                                    |                    |
| <b>Boost stage</b>           | 100              | 3524                       | 3987               | 14.0                            | 561                 | 345                 | 41                                 | 49                 |
| <b>Design levels</b>         | 80               | 3025                       | 3414               | 8.0                             | 349                 | 270                 | 37                                 | 45                 |
|                              | 60               | 2461                       | 2770               | 6.0                             | 244                 | 220                 | 29                                 | 37                 |
|                              | 40               | 1856                       | 2092               | 4.0                             | 173                 | 160                 | 21                                 | 29                 |
| <b>Minimum stage</b>         | 20               | 1132                       | 1346               | 3.0                             | 134                 | 115                 | < 20 <sup>4)</sup>                 | < 28 <sup>4)</sup> |
| <b>Natural convection</b>    |                  | 238                        | 277                | ---                             | ---                 | ---                 | ---                                | ---                |

Q<sub>N</sub> [W] = Standard heat output

Q [W] = Heat output

<sup>1)</sup> At room temperature t<sub>L</sub> = 20 °C

<sup>2)</sup> Add an additional power consumption of 1 W per valve drive type 146906.

<sup>3)</sup> The sound pressure levels were calculated with an assumed room insulation of 8 dB(A). This corresponds to a clearance of 2 m, a room volume of 100 m<sup>3</sup> and a reverberation time of 0.5 s (according to VDI 2081).

<sup>4)</sup> Sound pressure level < 20 dB (A) and sound power level < 28 dB (A) outside the usual measuring and audible range.

# 03 ▶ Design information

---



## Information on planning and design

Katherm QK nano are suitable for buildings of all kinds that require heating but have only limited space available in the floor.

In spite of their shallow height, Katherm QK nano can meet high heat loads in a space with assistance from whisper-quiet EC tangential fans.

They are generally positioned directly in front of the external façade without a gap. Katherm QK nano can provide cost-effective and efficient heating, particularly in front of large areas of glazing.

### Air outlet

All Katherm QK nano are positioned with the convector on the window side. The warm air rising up the exterior façade flows draught-free into the room, guaranteeing optimum cold air screening.

### Acoustics

The respective sound power levels of Katherm QK nano are indicated in the tables (see "Technical data"). The sound pressure levels were calculated with an assumed room insulation of 8 dB(A). This corresponds to a distance of 2 m, a room volume of 100 m<sup>3</sup> and a reverberation time of 0.5 s (in accordance with VDI 2081).

As the sound pressure level is not only due to the Katherm QK nano, but is also influenced by the number of Katherm QK nano and also very significantly by the acoustic characteristics of the room, the actual figure may vary in practice.

We would recommend designing Katherm QK nano taking into account the respective permitted sound pressure level in the room.

### Heat outputs

The heat outputs were calculated based on DIN EN 16430. We would recommend our online calculation programs to convert to other operating conditions at:  
[kampmann.co.uk/katherm-qk-nano/calculation](http://kampmann.co.uk/katherm-qk-nano/calculation)  
[kampmann.eu/katherm-qk-nano/calculation](http://kampmann.eu/katherm-qk-nano/calculation)

Make use of our online calculation programs to calculate your heat outputs and flow rates with a couple of clicks!

- ▶ [Kampmann.co.uk/kathermqknano/calculation](http://Kampmann.co.uk/kathermqknano/calculation)
- ▶ [Kampmann.eu/kathermqknano/calculation](http://Kampmann.eu/kathermqknano/calculation)

## Hydraulic set-up

Each model of the Katherm QK nano (24 V electromechanical, 230 V electromechanical or KaControl) offers two hydraulic set-up options with the optional accessory kits type 442100 and type 442101. Valve kit type 442100 can be used if valve control is planned in the trench convector. If the hydraulic system

is to be controlled via a central heating circuit distributor, connection kit type 442101 can be used to shut off the copper-aluminium convector.

### Decentralised valve control

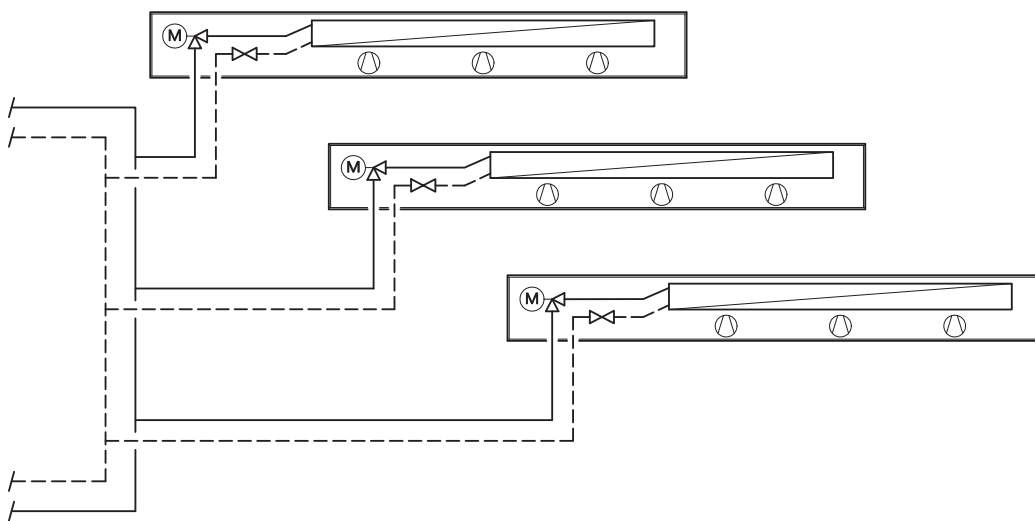

Valve kit type 442100 must be ordered separately.

### Central heating circuit distributor

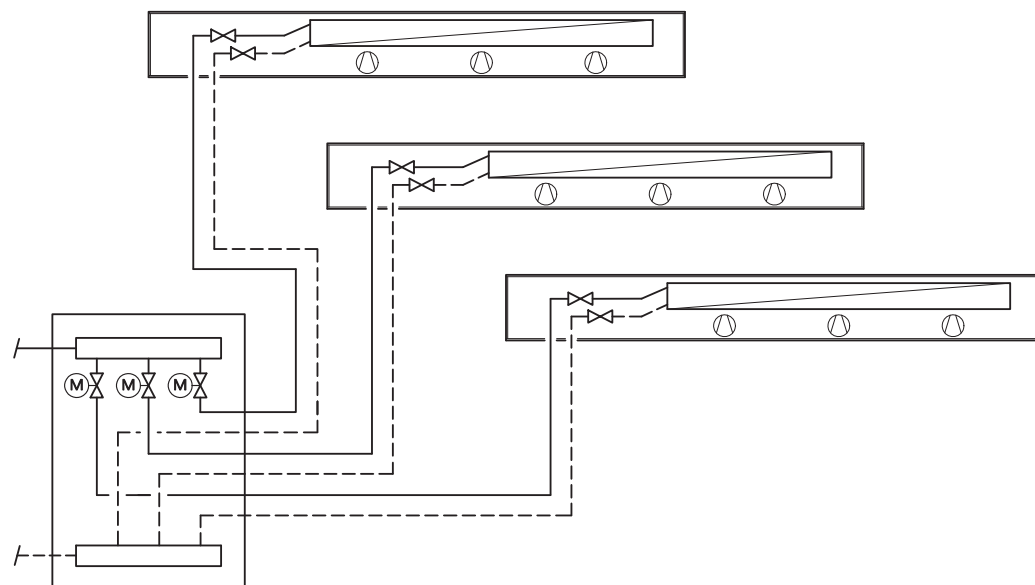

Valve kit type 442101 must be ordered separately.

# 04 ▶ Controls

Three different control options are available for the Katherm QK nano for ease of integration into individual control schemes. The space-saving 24 V versions permits direct connection to on-site building management systems. An electromechanical control option using a room thermostat or alternatively the KaControl system are both available for continuously

variable control with 230 V supply voltage. KaControl represents the system solution for maximum energy efficiency, limitless integration options into building automation systems and the highest degree of user-friendly operating philosophy.

## 24 V electromechanical model

Model for complete on-site control of trench convectors.

### Product features

- ▶ The operating voltage must be provided by a central on-site 24 V DC voltage supply.
- ▶ The external voltage supply results in a shortened, space-saving connection area within the trench convector, producing the same output from a shorter trench length.
- ▶ Kampmann offers a range of switching power units in different output classes as accessories for the voltage supply (24 V DC).
- ▶ The fan automatically switches off in the event of a motor fault.

Table with rating values

| Trench length [mm] | QK nano<br>Power consumption P [W]<br>Current consumption I [mA]<br>at fan speed |    |     |    |     |     |     |     |      |     |
|--------------------|--|----|-----|----|-----|-----|-----|-----|------|-----|
|                    | 20%  |    | 40% |    | 60% |     | 80% |     | 100% |     |
| 900                | 1.0  | 17 | 1.0 | 33 | 2.0 | 63  | 3.0 | 109 | 5.0  | 208 |
| 1400               | 1.0  | 23 | 1.0 | 41 | 2.0 | 75  | 3.0 | 125 | 6.0  | 227 |
| 1800               | 1.0  | 30 | 2.0 | 51 | 3.0 | 89  | 4.0 | 147 | 7.0  | 258 |
| 2100               | 1.0  | 41 | 2.0 | 68 | 3.0 | 121 | 6.0 | 212 | 8.0  | 333 |
| 2600               | 2.0  | 51 | 3.0 | 89 | 5.0 | 161 | 7.0 | 265 | 13.0 | 477 |

The power and current consumption of the actuators (1 W) is not taken into account.

## Electrical cabling - BMS control

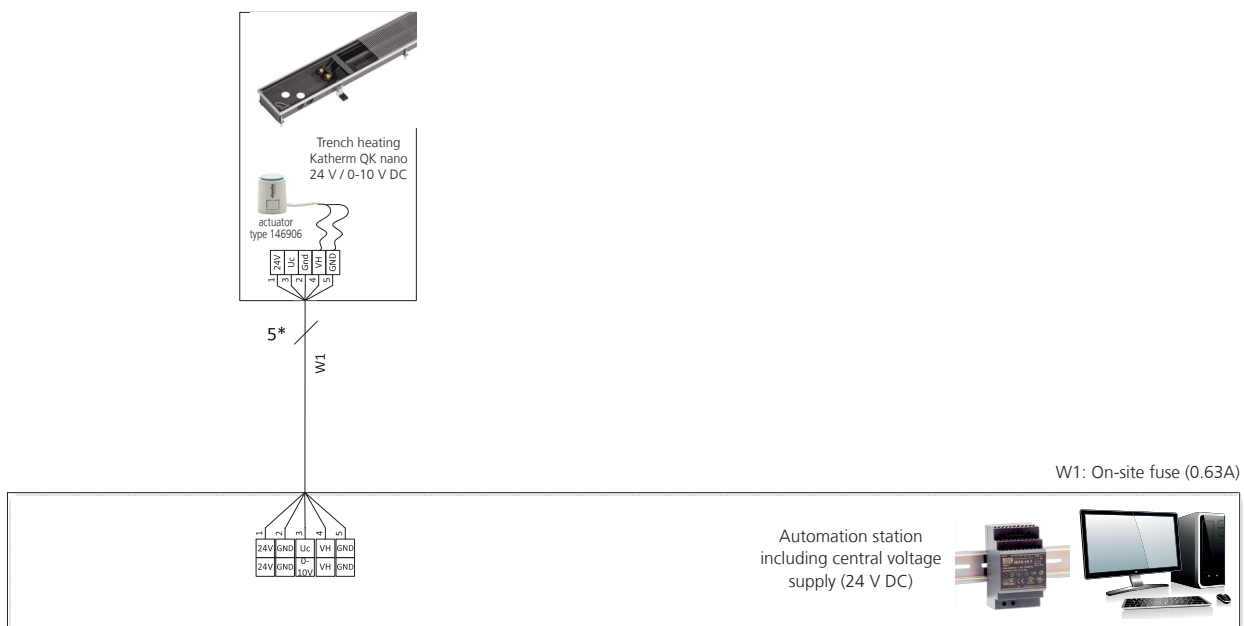

\* Lay shielded cables (e.g. IY(ST)Y, 0.8 mm), separately from high-voltage cables.

W1: Voltage supply and control signal for fan (on-site fuse 0.63 A) and actuator.

Subject to technical modifications: Refer to the control accessory documentation in the event of deviation from the circuit diagrams!

## Electrical cabling – control via clock thermostat, type 30456

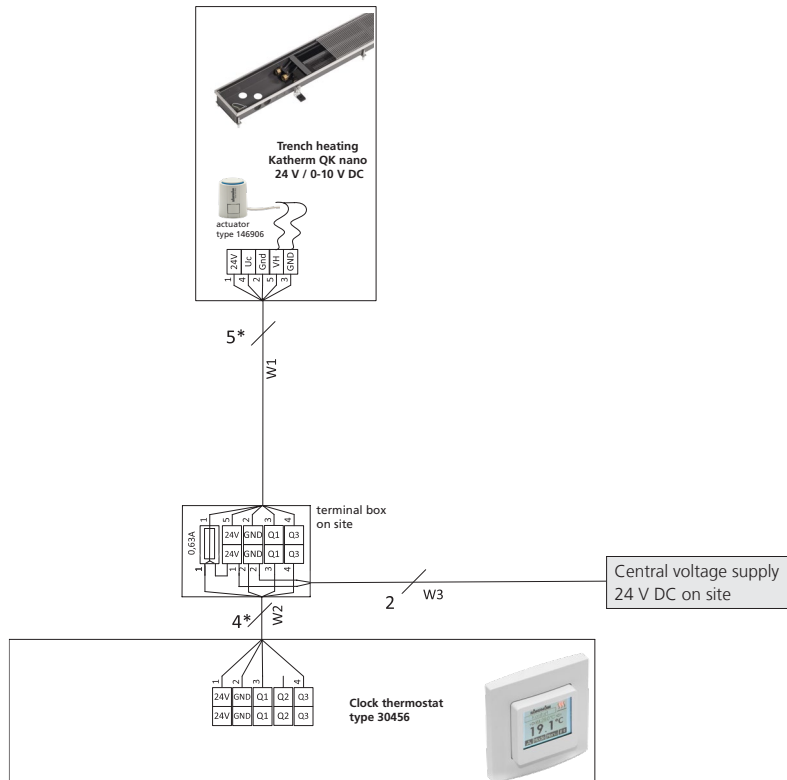

- \* Lay shielded cables (e.g. IY(ST)Y, 0.8 mm), separately from high-voltage cables.
- W1: Voltage supply and control signal for fan (on-site fuse 0.63 A) and actuator.
- W2: Voltage supply and control signal for fan and actuator.
- W3: Voltage supply (fuse by others).



# 230 V electromechanical model

Design for on-site control or for room regulation with intuitive operation of the trench convectors.

### Product features

- ▶ The Katherm QK nano features an integral switch power supply to connect to the 230 V AC voltage supply.
- ▶ In the event of a motor fault, the fan automatically switches off and a fault signal is issued at a potential-free contact.
- ▶ Kampmann offers an extensive range of control accessories for all required functions.

Table with rating values

| Trench length [mm] | QK nano<br>Power consumption P [W]<br>Current consumption I [mA]<br>at fan speed |     |     |     |     |     |     |     |      |     |
|--------------------|--|-----|-----|-----|-----|-----|-----|-----|------|-----|
|                    | 20%  |     | 40% |     | 60% |     | 80% |     | 100% |     |
| 1100               | 2.0  | 59  | 2.0 | 74  | 3.0 | 105 | 4.0 | 151 | 6.0  | 249 |
| 1600               | 2.0  | 65  | 2.0 | 83  | 3.0 | 117 | 4.0 | 166 | 7.0  | 269 |
| 2000               | 2.0  | 71  | 3.0 | 93  | 4.0 | 131 | 5.0 | 188 | 8.0  | 299 |
| 2300               | 2.0  | 83  | 3.0 | 110 | 4.0 | 163 | 7.0 | 253 | 9.0  | 375 |
| 2700               | 3.0  | 134 | 4.0 | 173 | 6.0 | 244 | 8.0 | 349 | 14.0 | 561 |

The power and current consumption of the actuators (1 W) is not taken into account.

## Electrical cabling - BMS control

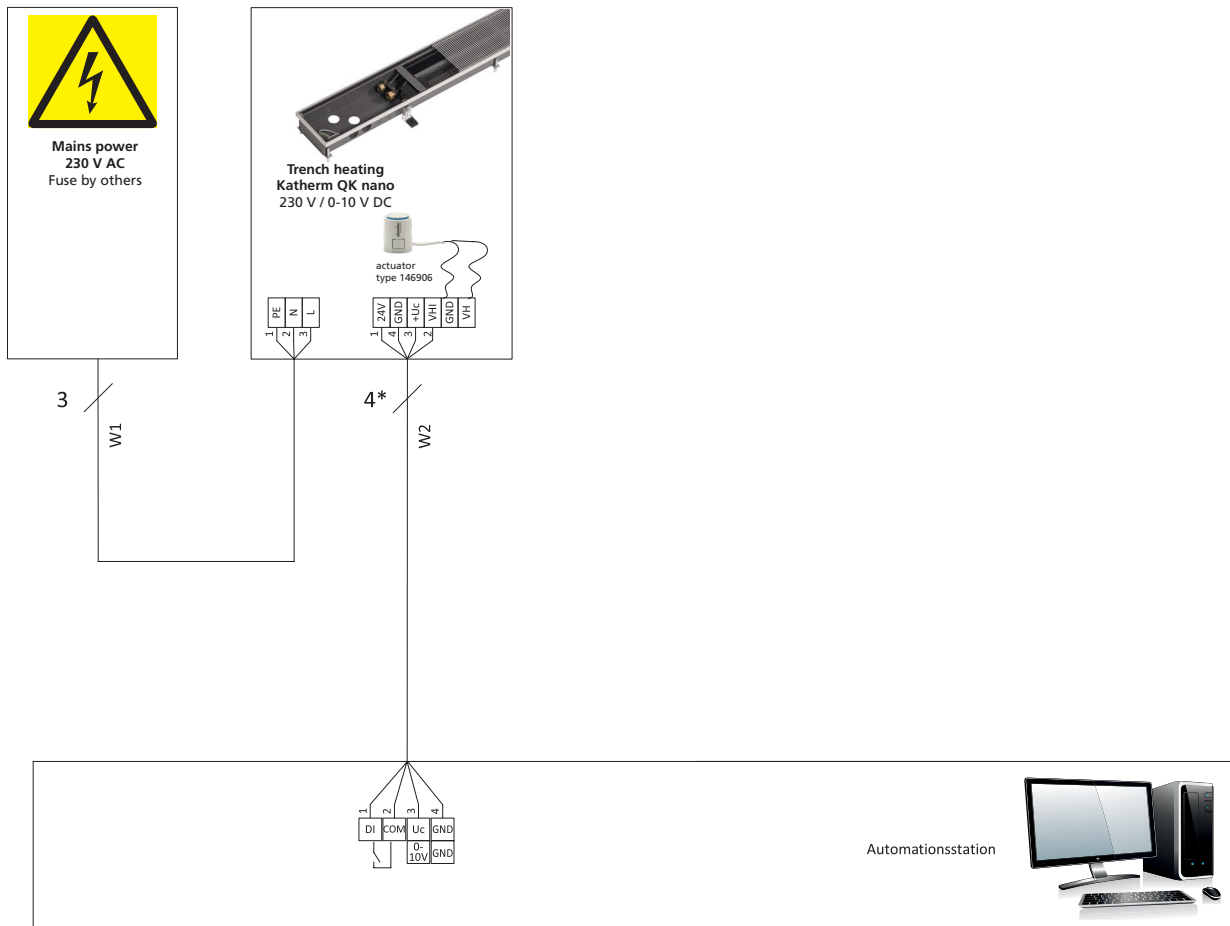

\* Lay shielded cables (e.g. IY(ST)Y, 0.8 mm), separately from high-voltage cables.

W1: Power supply

W2: Control signal for fan and actuator

Subject to technical modifications: Refer to the control accessory documentation in the event of deviation from the circuit diagrams!

## Electrical cabling – control via room thermostat, type 342924

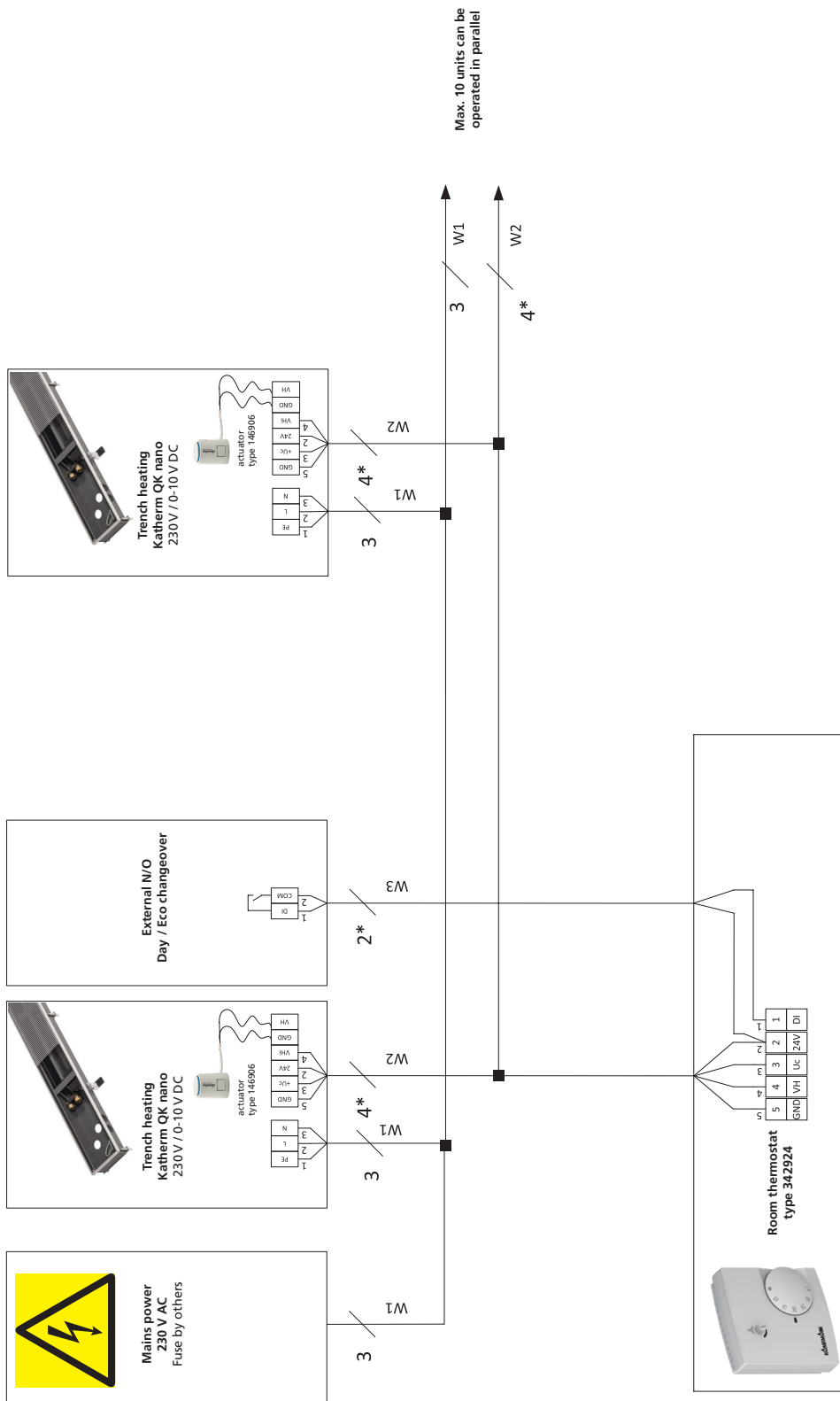

\* Lay shielded cables (e.g. IY(ST)Y, 0.8 mm), separately from high-voltage cables.

W1: Power supply

W2: Control signal for fan and actuator

W3: Operating mode changeover (optional)

Subject to technical modifications: Refer to the control accessory documentation in the event of deviation from the circuit diagrams!

## KaControl model

The all-inclusive solution for room automation and networking

### Product features

- ▶ A high-performance parametrised microprocessor is designed to carry out all necessary functions. Each Katherm QK nano unit therefore is equipped with its own "intelligence" and can be operated in groups via Kampmann networks.

### Connection to building automation systems

- ▶ Katherm QK nano units with KaControl can be equipped with plug-in communication interfaces for individual room control or for linking into higher-order control systems: BACnet, CAN bus, LON, KNX and Modbus. Direct control via an active 0-10 V signal from the on-site building management system is alternatively possible.

### Motor protection

- ▶ Any faults with the motor e.g. overloading are analysed by the electronics within the EC motor. This then switches the fan off.

### KaControl

The parametrisable KaControl offers a wide range of functions:

- ▶ optional: 5 fan speed settings; manually adjustable
- ▶ valve control for 2-pipe applications for thermoelectric valve actuators 24 V DC OPEN/CLOSE
- ▶ integrated timer program for programming day and week switching functions in the KaController unit
- ▶ motor monitoring with fault signal processing

### KaController operating unit



The "face" of the KaControl building automation system: the KaController operating unit.

With a large display and one-touch operation, the KaController is very easy to use. With the basic principle, "as little as possible, as much as required", even untrained users can intuitively get to grips with the control options.

The basic functions for comfortable interior temperatures are set in a user-friendly way using the KaController.

### Product features

- ▶ room control unit, wall-mounted, high-grade design
- ▶ available with or without function buttons on the side
- ▶ plastic housing, colour similar to RAL 9010
- ▶ communication interface to Kampmann T-LAN bus system
- ▶ large display with automatic back light
- ▶ integral room temperature sensor
- ▶ push-turn navigator dial with endless turn/lock function
- ▶ built-in weekly switching program
- ▶ password-protected parameter level

Table with rating values

| Trench length [mm] | QK nano<br>Power consumption P [W]<br>Current consumption I [mA]<br>at fan speed |     |     |     |     |     |     |     |      |     |
|--------------------|--|-----|-----|-----|-----|-----|-----|-----|------|-----|
|                    | 20%  |     | 40% |     | 60% |     | 80% |     | 100% |     |
| 1100               | 2.0  | 59  | 2.0 | 74  | 3.0 | 105 | 4.0 | 151 | 6.0  | 249 |
| 1600               | 2.0  | 65  | 2.0 | 83  | 3.0 | 117 | 4.0 | 166 | 7.0  | 269 |
| 2000               | 2.0  | 71  | 3.0 | 93  | 4.0 | 131 | 5.0 | 188 | 8.0  | 299 |
| 2300               | 2.0  | 83  | 3.0 | 110 | 4.0 | 163 | 7.0 | 253 | 9.0  | 375 |
| 2700               | 3.0  | 134 | 4.0 | 173 | 6.0 | 244 | 8.0 | 349 | 14.0 | 561 |

The power and current consumption of the actuators (1 W) is not taken into account.

## Electrical cabling - 24 V Open / Close valve, external KaController

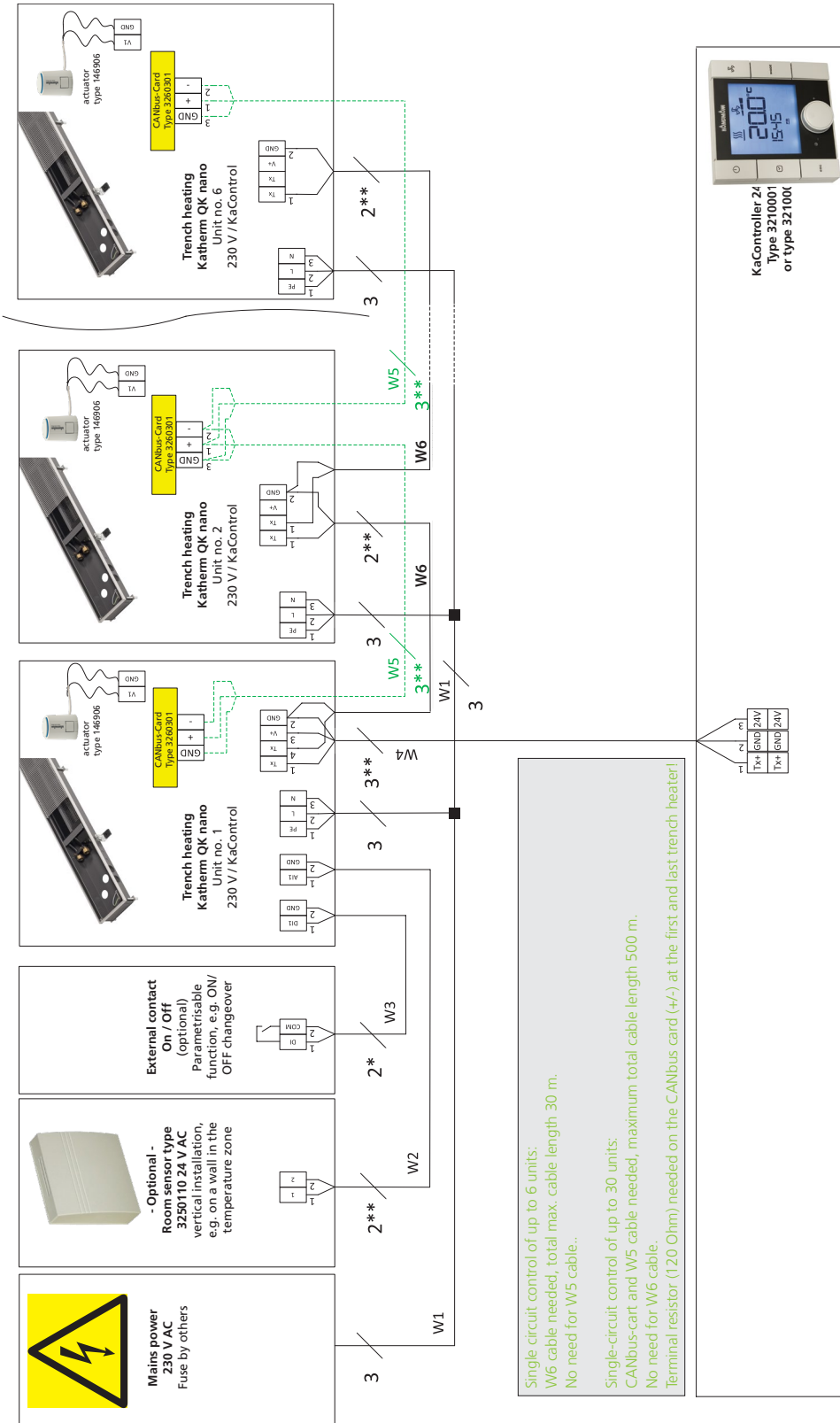

\* Lay shielded cables (e.g. IY(ST)Y 0,8 mm) separately from high-voltage cables.

\*\* Lay shielded, paired cables, e.g. UNITRONIC® BUS LD 2x2x0,22 or equivalent, separately from high-voltage cables.

W1: Power supply

W2: Analogue input AI1 (optional connection), max. cable length 10 m, from 1 mm² 30 m.

W3: Digital input DI1 (optional connection), max. cable length 30 m, from 1 mm² 100 m.

W4/W6: Bus signal (tLan), each max. total cable length 30 m.

W5: Bus signal (CANbus) only needed in a single-circuit control of up to 30 units.

Subject to technical modifications: Refer to the control accessory documentation in the event of deviation from the circuit diagrams!

## Cabling with control electronics type 3231131

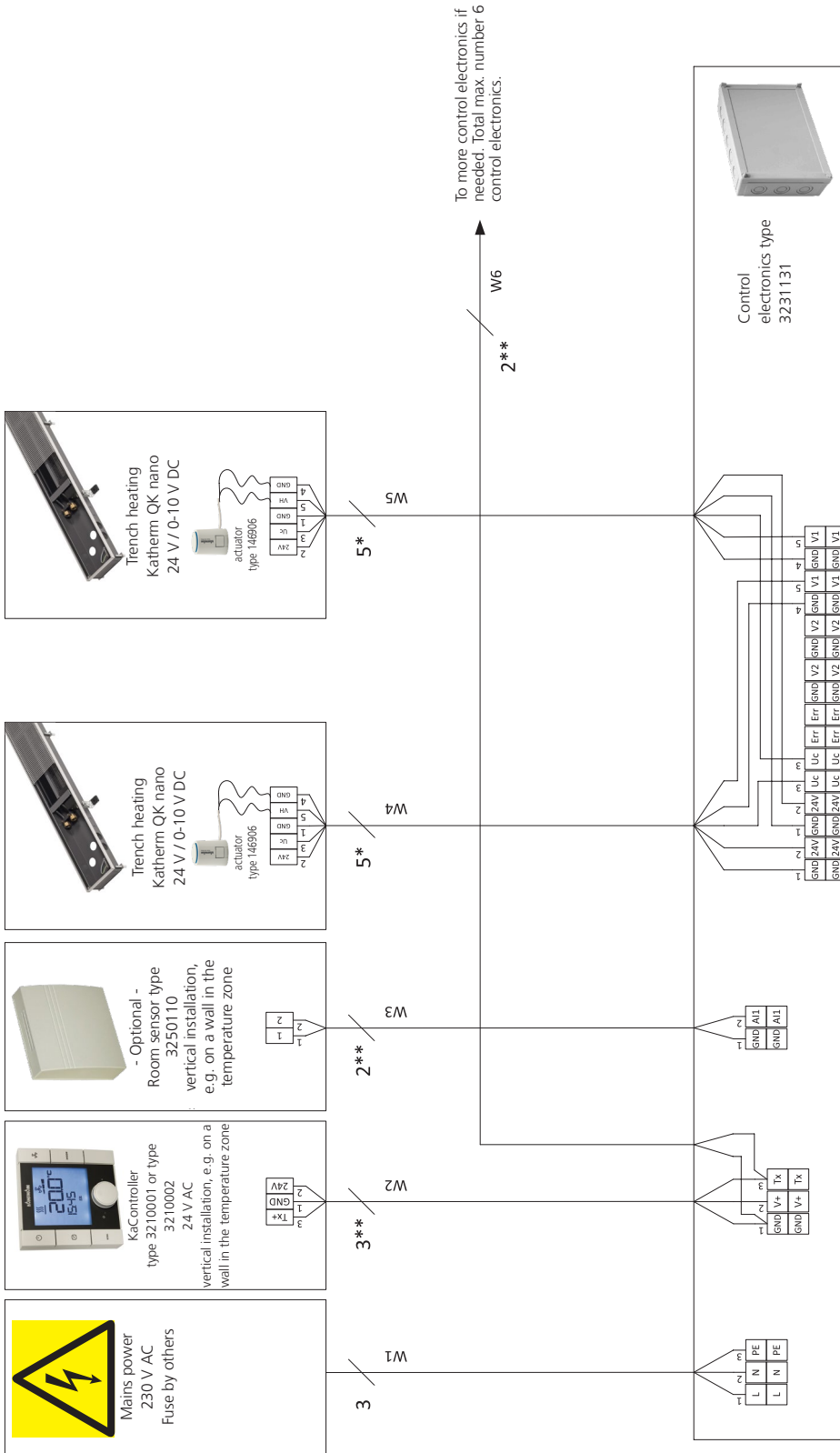

## Cabling with control electronics type 3231132

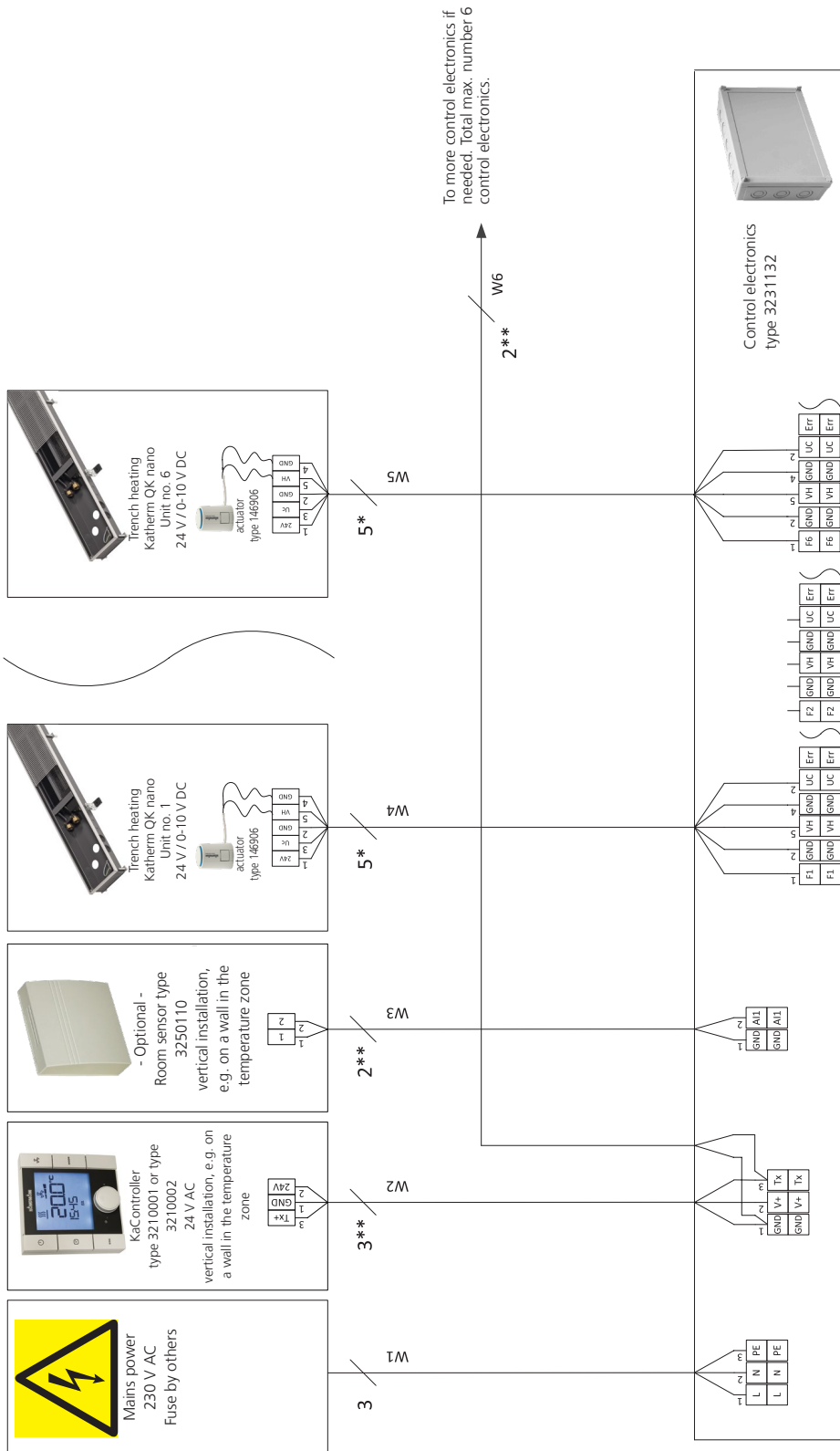

\* Lay shielded cables (e.g. IY(ST)Y, 0.8 mm), separately from high-voltage cables.  
 \*\* Lay shielded, paired cables, e.g. CAT5 (AWG23) of at least the same value, separately from high-voltage cables.  
 W1: Power supply  
 W2: Bus signal (tLan)  
 W3: Analogue input A11 (optional connection)  
 W4: Control signal for fan and actuator, total maximum cable length 10 m  
 W5: Control signal for fan and actuator, total maximum cable length 10 m  
 W6: Bus signal (tLan)  
 Subject to technical modifications: Refer to the control accessory documentation in the event of deviation from the circuit diagrams!



# 05 ▶ Ordering information

## Katherm QK nano

| Trench height                          | Trench width | Trench length | Grille finish | Art. no.                       |
|--|--------------|---------------|---------------|--------------------------------|
| [mm]                                   | [mm]         | [mm]          |               |                                |
| <b>24 V electromechanical control</b>  |              |               |               |                                |
| 70                                     | 165          | 900           | FineLine Q    | <b>44217072</b> 23 <b>1324</b> |
|  |              |               | FineLine L    | <b>44217074</b> 23 <b>1324</b> |
|  |              | 1400          | FineLine Q    | <b>44217072</b> 23 <b>2324</b> |
|  |              |               | FineLine L    | <b>44217074</b> 23 <b>2324</b> |
|  |              | 1800          | FineLine Q    | <b>44217072</b> 23 <b>3124</b> |
|  |              |               | FineLine L    | <b>44217074</b> 23 <b>3124</b> |
|  |              | 2100          | FineLine Q    | <b>44217072</b> 23 <b>3724</b> |
|  |              |               | FineLine L    | <b>44217074</b> 23 <b>3724</b> |
|  |              | 2600          | FineLine Q    | <b>44217072</b> 23 <b>4724</b> |
|  |              |               | FineLine L    | <b>44217074</b> 23 <b>4724</b> |
| <b>230 V electromechanical control</b> |              |               |               |                                |
| 70                                     | 165          | 1100          | FineLine Q    | <b>44217072</b> 23 <b>1700</b> |
|  |              |               | FineLine L    | <b>44217074</b> 23 <b>1700</b> |
|  |              | 1600          | FineLine Q    | <b>44217072</b> 23 <b>2700</b> |
|  |              |               | FineLine L    | <b>44217074</b> 23 <b>2700</b> |
|  |              | 2000          | FineLine Q    | <b>44217072</b> 23 <b>3500</b> |
|  |              |               | FineLine L    | <b>44217074</b> 23 <b>3500</b> |
|  |              | 2300          | FineLine Q    | <b>44217072</b> 23 <b>4100</b> |
|  |              |               | FineLine L    | <b>44217074</b> 23 <b>4100</b> |
|  |              | 2700          | FineLine Q    | <b>44217072</b> 23 <b>4900</b> |
|  |              |               | FineLine L    | <b>44217074</b> 23 <b>4900</b> |
| <b>KaControl</b>                       |              |               |               |                                |
| 70                                     | 165          | 1100          | FineLine Q    | <b>44217072</b> 23 <b>17C1</b> |
|  |              |               | FineLine L    | <b>44217074</b> 23 <b>17C1</b> |
|  |              | 1600          | FineLine Q    | <b>44217072</b> 23 <b>27C1</b> |
|  |              |               | FineLine L    | <b>44217074</b> 23 <b>27C1</b> |
|  |              | 2000          | FineLine Q    | <b>44217072</b> 23 <b>35C1</b> |
|  |              |               | FineLine L    | <b>44217074</b> 23 <b>35C1</b> |
|  |              | 2300          | FineLine Q    | <b>44217072</b> 23 <b>41C1</b> |
|  |              |               | FineLine L    | <b>44217074</b> 23 <b>41C1</b> |
|  |              | 2700          | FineLine Q    | <b>44217072</b> 23 <b>49C1</b> |
|  |              |               | FineLine L    | <b>44217074</b> 23 <b>49C1</b> |

As standard, Katherm QK nano are supplied with a FineLine Q-grille powder coated in RAL 9006 (white aluminium). This can be replaced by one of the following grilles at a surcharge. Please change the two red digits in the article number to select an alternative grille.

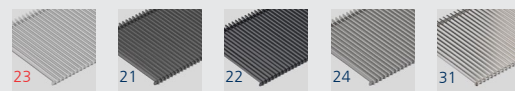

**Article key for grille finish** (example of art. no.)

0 →  
**44217072**23**1324** —→ Steel, coated RAL 9006 (standard)  
**21** —→ Steel, coated DB 703  
**22** —→ Steel, coated RAL 9005  
**24** —→ Steel, coated RAL 9007  
**31** —→ Stainless steel, natural





The above grilles are shown using a four-colour printing process and thus do not represent an exact reproduction of the original colour.





## Accessories

| Figure  | Article  | Properties  | Suitable for                                   | Art. no.            |
|---|--|---|--|---------------------|
| <b>Connecting accessories</b>   |  |   |  |                     |
|    | <b>Valve kit</b><br>Valve body, 24 V actuator and return fitting | Valve body, axial, 1/2" connection, pre-settable, return shut-off valve, straight, 1/2" connection, 24 V thermoelectric actuator, connecting piece  | all Katherm QK nano                            | <b>194000442100</b> |
|   | <b>Connection kit</b><br>2 return fittings                       | 2 return shut-off valves, straight, 1/2" connection, connecting piece, for use on the Katherm QK nano with a central heating circuit distributor  |  | <b>194000442101</b> |
| <b>24 V electromechanical control accessories</b>                                   |  |   |  |                     |
|  | <b>Power unit</b><br>for max. 3 Katherm QK nano                  | 230 V AC/24 V: for max. 3 Katherm QK nano 24 V model, for external installation outside the trench convector  | Katherm QK nano, electromechanical 24 V model  | <b>196901335152</b> |
|  | <b>Power unit</b><br>for max. 5 Katherm QK nano                  | 230 V AC/24 V: for max. 5 Katherm QK nano 24 V model, for external installation outside the trench convector  |  | <b>196901338401</b> |
|  | <b>Power unit</b><br>for max. 7 Katherm QK nano                  | 230 V AC/24 V: for max. 7 Katherm QK nano 24 V model, for external installation outside the trench convector  |  | <b>196901338402</b> |
| <b>230 V electromechanical control accessories</b>                                  |  |   |  |                     |
|  | <b>Room thermostat type 342924</b>                               | Continuously variable speed controller combined with a thermostat for room temperature-dependent two-point control of Katherm QK nano units. The fan speed is set manually on the speed controller at between 0-100%. The thermostats activate the Katherm QK nano according to the temperature at the pre-set speed. | Katherm QK nano, 230 V electromechanical model | <b>194000342924</b> |
| <b>24 V electromechanical control accessories</b>                                   |  |   |  |                     |
|  | <b>Clock thermostat type 30456</b>                               | Clock thermostat 24 V, heating/cooling with 2-pipe system, flush-mounted, continuously variable, with LCD operating menu and integrated timer program, heating/cooling changeover by means of external potential-free contact (low voltage)   | Katherm QK nano, 24 V electromechanical model  | <b>196000030456</b> |

## Accessories

| Figure  | Article  | Properties   | Suitable for                        | Art. no.            |
|---|--|--|-------------------------------------|---------------------|
| <b>KaControl accessories</b>  |  |  |                                     |                     |
|    | <b>KaController operating unit</b><br>with one-touch operation | Operating unit, wall-mounted, in high-grade design, plastic housing, colour similar to RAL 9010, large LCD multifunctional display, integrated room temperature sensor, communication interface to Kampmann T-LAN bus system, automatically switching LED backlight, press/turn dial with click stop function, individually adjustable basic display, integrated day, night and week program, password-protected parameter level for C1 control option | Katherm QK nano,<br>KaControl model | <b>196003210001</b> |
|  | <b>KaController operating unit</b><br>with side function keys  | For quick access to fan setting, operating modes, Eco mode, time and timer program, otherwise as art. no. 196003210001   | Katherm QK nano,<br>KaControl model | <b>196003210002</b> |
|  | <b>KaController operating unit</b><br>with one-touch operation | Room control unit for wall mounting, high-quality design, plastic housing, colour similar to RAL 9017, otherwise as art. no. 169003210001  | Katherm QK nano,<br>KaControl model | <b>196003210006</b> |
|  | <b>Room temperature sensor</b>                                 | For wall mounting, IP30 surface-mounted, white RAL 9010, alternative to the temperature sensor in the KaController   | Katherm QK nano,<br>KaControl model | <b>196003250110</b> |
|  | <b>Serial CANBus card</b>                                      | For increasing the number of units in a single-circuit system to a maximum of 30 units, 1 x required per Katherm QK nano unit  | Katherm QK nano,<br>KaControl model | <b>196003260301</b> |
|  | <b>Serial Modbus card</b>                                      | For connection to Modbus networks  | Katherm QK nano,<br>KaControl model | <b>196003260101</b> |
|  | <b>Serial KNX card</b>   | For integration into KNX/EIB networks  | Katherm QK nano,<br>KaControl model | <b>196003260701</b> |

[more »](#)

| Figure  | Article                      | Properties   | Suitable for                | Art. no.            |
|---|------------------------------|--|-----------------------------|---------------------|
|    | <b>KaControl electronics</b> | For the operation of max. 2 Katherm QK nano 24 V models, for external installation outside the trench heater | Katherm QK nano, 24 V model | <b>196003231131</b> |
|   |                              | For the operation of max. 6 Katherm QK nano 24 V models, for external installation outside the trench heater |                             | <b>196003231132</b> |
| <b>Other accessories</b>  |                              |  |                             |                     |
|  | <b>Installation cover</b>    | Made of wood to provide protection during installation, factory-fitted<br>Grilles are supplied separately    | All Katherm QK nano         | <b>194000101916</b> |

# Katherm QK at a glance

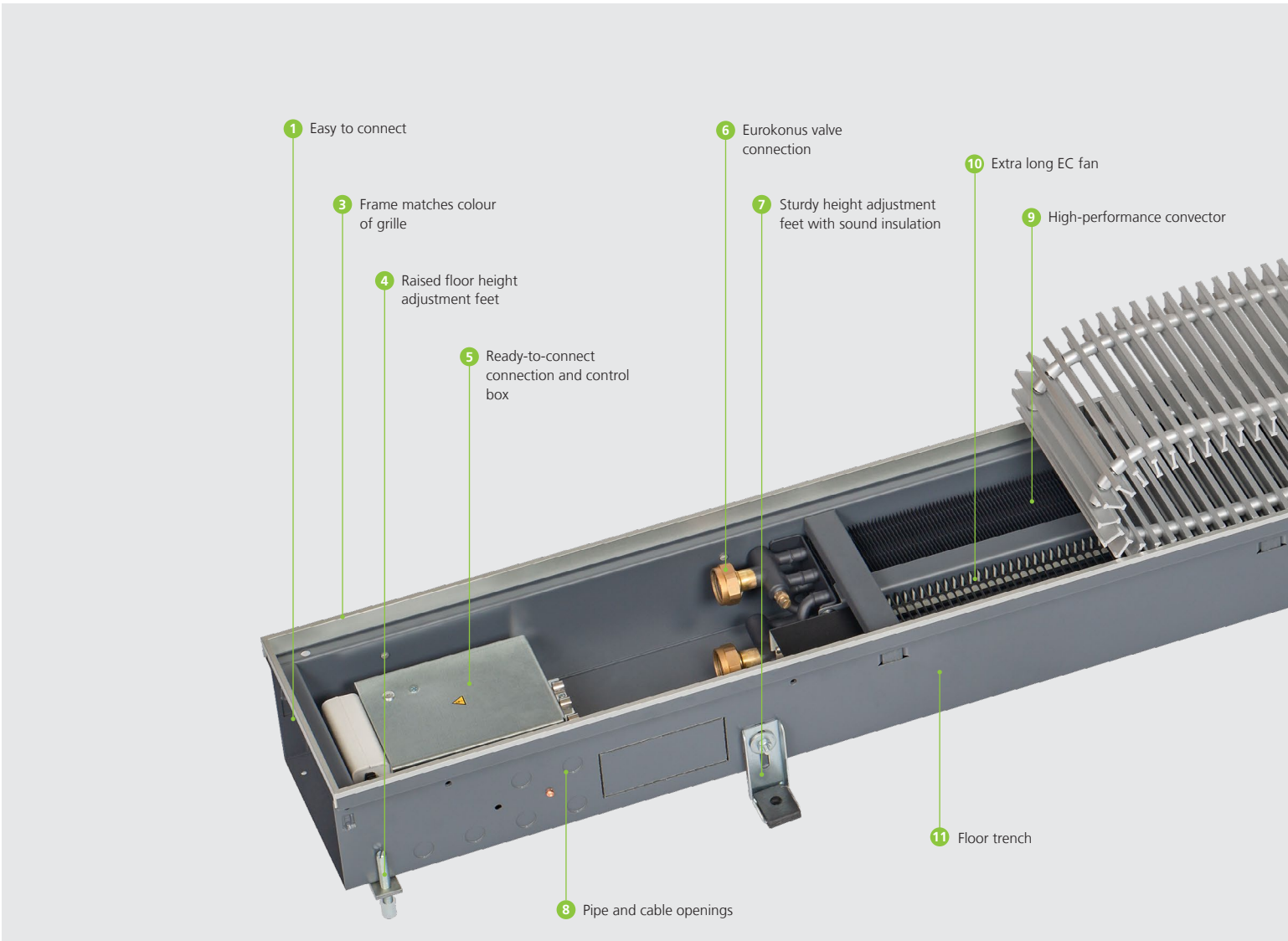

## Features

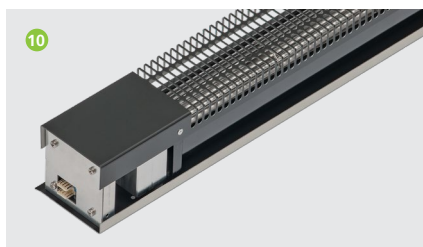

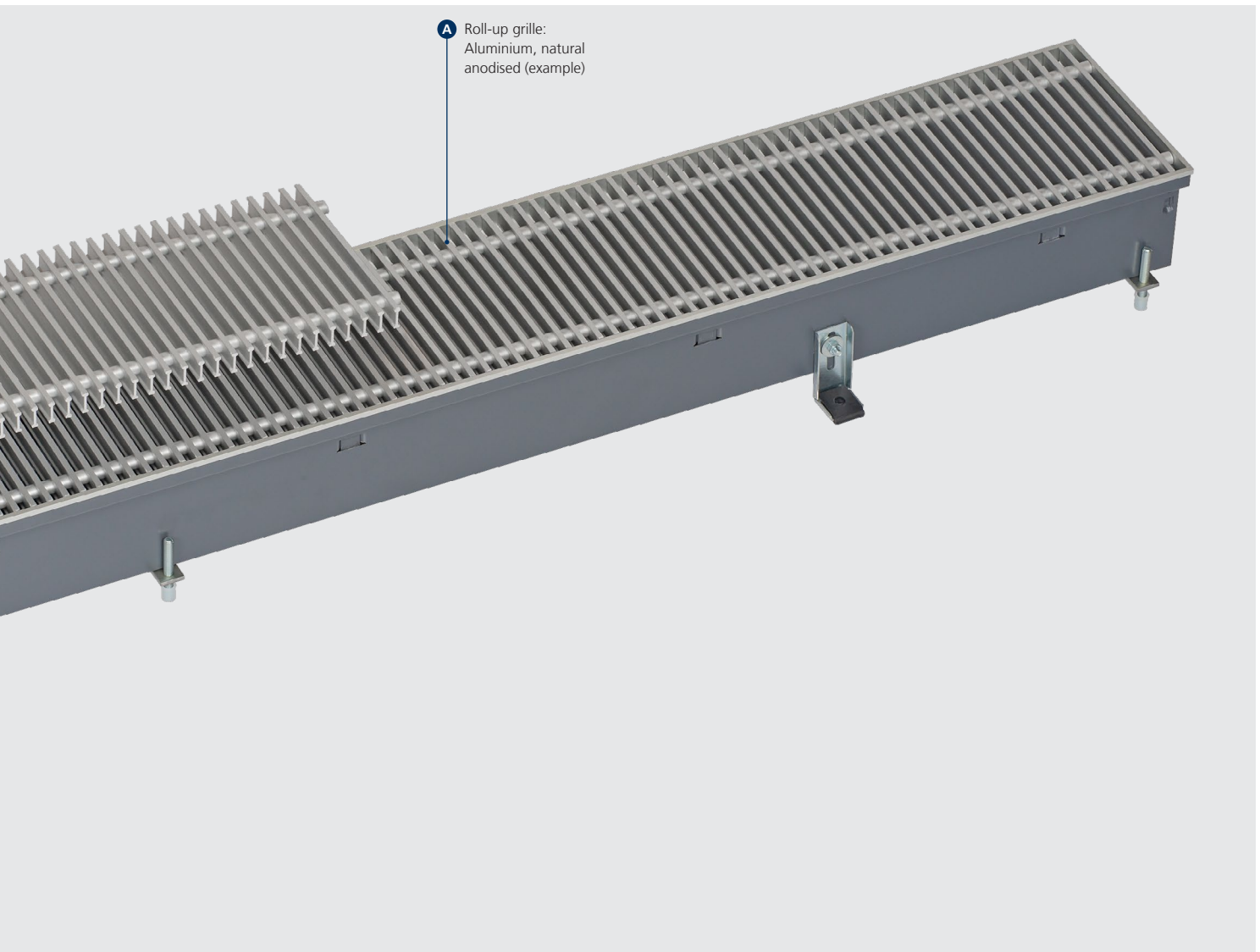

- 1 **Easy to connect**
  - ▶ removable end panel for ease of connection of trenches
- 2 **Cover plate**
  - ▶ as visual protection and to protect against dirt
- 3 **Frame matches colour of grille**
- 4 **Load-bearing height adjustment feet**
  - ▶ for the safe and standard mounting of the trench
- 5 **Ready-to-connect connection and control box**
  - ▶ for quick and safe electrical connection
  - ▶ saves installation time
  - ▶ for Ka-Control C1 and 230 V electromechanical -00 control options
  - ▶ including 230/24 V power unit
- 6 **Eurokonus valve connection**
  - ▶ for fast connection
  - ▶ saves installation time
- 7 **Sturdy height adjustment feet**  
**Impact sound insulation**
  - ▶ for the simple fixing of the floor trench
  - ▶ prevents sound transmission
- 8 **Pipe and cable openings**
  - ▶ for water and electrical connections
  - ▶ punched
- 9 **High-performance convector:**
  - ▶ proven combination of copper/aluminium
  - ▶ optimised for air flow and heat dissipation
  - ▶ graphite-grey coated
- 10 **Extra-long EC fan**
  - ▶ for an even airflow through the convector, providing high heat outputs with low noise emissions
  - ▶ robust motor design
  - ▶ continuously variable speed control via an external 0 – 10V signal
  - ▶ motor monitoring with internal fault processing
- 11 **Floor trench**
  - ▶ galvanised sheet steel
  - ▶ graphite-grey coated on both sides
  - ▶ with cross bracing to reinforce the floor trench
- 12 **Electrical wiring**
  - ▶ 24 V electromechanical model -24
- A **Aluminium roll-up grille, natural anodised**
  - ▶ double T-profile roll-up or linear grille
  - ▶ bar dimension 18 x 5 mm (stainless steel 18 x 6 mm)
  - ▶ bar spacing 12 mm, free area approx. 70% (aluminium anodised, brass)
  - ▶ bar spacing 10.5 mm, free area approx. 65% (stainless steel)
  - ▶ connections made of corrosion-proof steel springs with spacers in a matching colour
  - ▶ roll-up or linear grilles with 9 mm bar spacing, free area approx. 65% (aluminium, anodised, brass) optionally available

## Matching grilles

### Optiline roll-up grilles

**Aluminium**  
Natural anodised

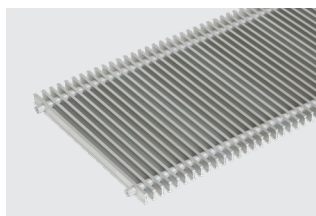

**Aluminium**  
Brass anodised

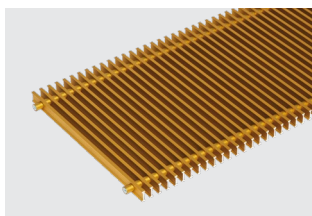

**Aluminium**  
Bronze anodised



**Aluminium**  
Black anodised

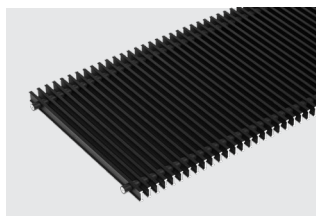

**Aluminium**  
Light Bronze

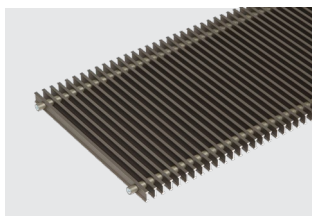

**Aluminium**  
Coated DB 703

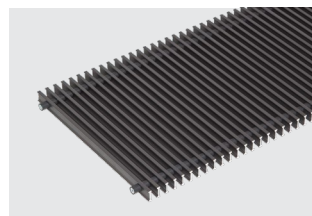

**Stainless steel**  
Natural

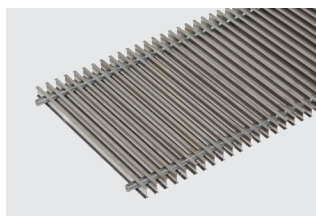

**Stainless steel**  
Polished

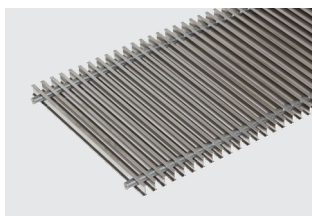

**Brass**  
Natural CuZn 44

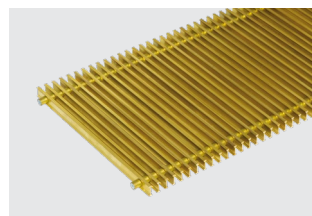

## Linear grilles, Optiline

**Aluminium**  
Natural anodised

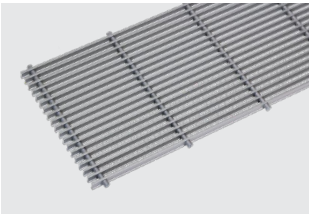

**Aluminium**  
Brass anodised

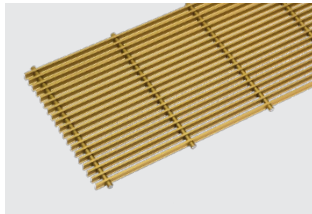

**Aluminium**  
Bronze anodised

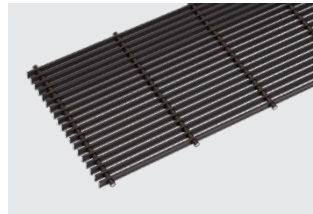

**Aluminium**  
Light Bronze

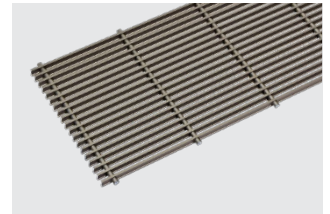

► For more grilles, please visit  
[Kampmann.co.uk/grilles](http://Kampmann.co.uk/grilles)

The above grilles are shown using a four-colour printing process and thus do not represent an exact reproduction of the original colour.

## Optiline double-T profile dimensions

| Optiline double-T profile  | Figure | Bar spacing, free area  |
|----------------------------|--------|-------------------------|
| Aluminium, anodised brass  |        | 12 mm<br>approx. 70%    |
| Aluminium, anodised, brass |        | 9 mm<br>approx. 65 %    |
| Stainless steel            |        | 10.5 mm<br>approx. 65 % |

## 02 ▶ Technical data

---

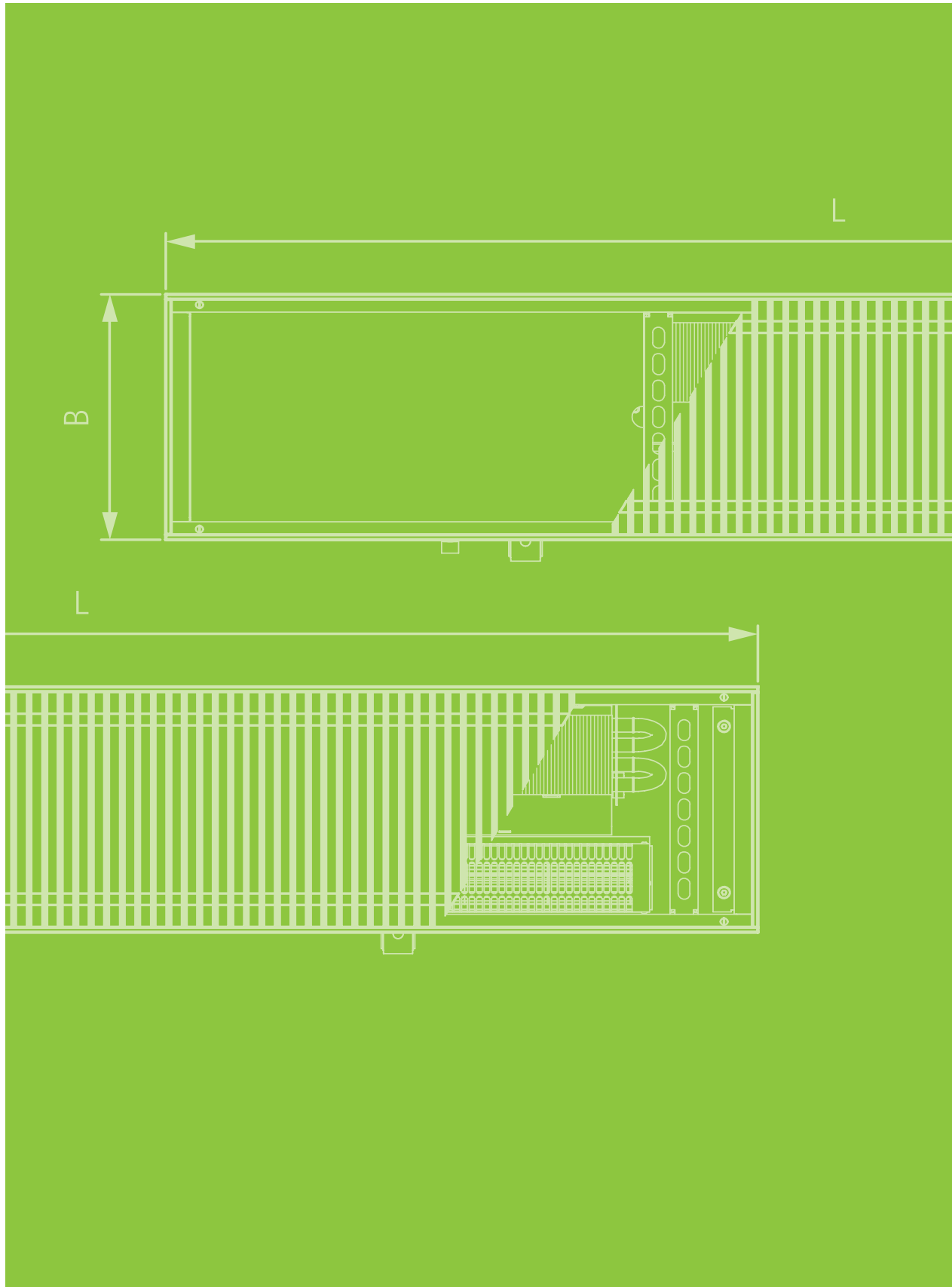



## Advice on measuring conditions

### Heat outputs

The heat outputs were measured and determined in accordance with DIN EN 16430 “Fan-assisted radiators, convectors and trench convectors”.

Part 1 “Technical specifications and requirements”  
Part 2 “Test method and evaluation of heat output”

The specific requirements for trench heating are taken into account in DIN EN 16430. The reference/air temperature is measured in the centre of the test chamber (2 metres from the external wall) at a height of 0.75 metres. The surface temperature of the façade is 16°C. Experience has shown that the underfloor convector is positioned at a distance of 50 mm from the façade.

### Acoustics

Katherm QK are very often used in acoustically sensitive areas. Accordingly, Katherm QK have been optimised in terms of noise levels. (Determination of the sound power and sound energy levels of sources of sound from sound pressure measurements – precision 2 class of enveloping measurement surface for an essentially free sound field over a reflective plane). The sound power level is measured according to DIN EN ISO 3744 in a semi-low reflective sound measuring chamber.



Acoustic measuring chamber

# Katherm QK 190

Technical drawings (all dimensions in mm)

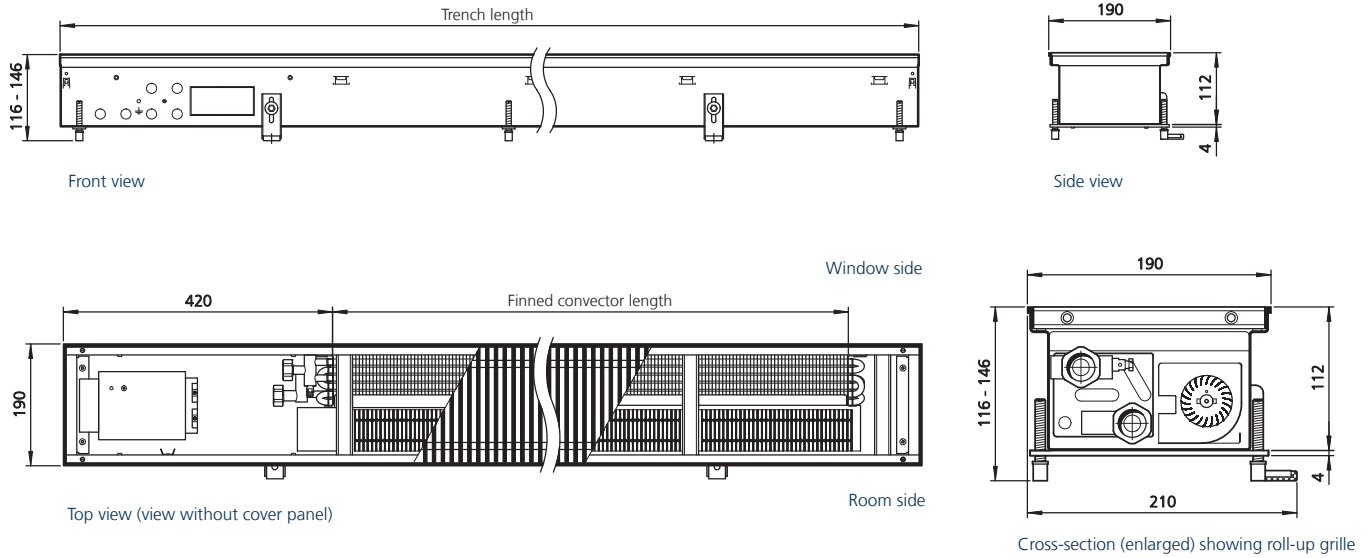

| Trench length | Finned convector length |
|---------------|-------------------------|
| [mm]          | [mm]                    |
| 1000          | 430                     |
| 1200          | 665                     |
| 1400          | 865                     |
| 1600          | 1100                    |
| 1800          | 1300                    |
| 2000          | 1300                    |

| Trench length | Finned convector length |
|---------------|-------------------------|
| [mm]          | [mm]                    |
| 2200          | 1640                    |
| 2400          | 1840                    |
| 2600          | 2075                    |
| 2800          | 2275                    |
| 3000          | 2510                    |
| 3200          | 2710                    |

## Specifications

### Connections, female thread:

Eurokonus, same end, connections on left

Make use of our online calculation programs to calculate your heat outputs and flow rates with a couple of clicks!

- ▶ [Kampmann.co.uk/katherm-qk/calculation](http://Kampmann.co.uk/katherm-qk/calculation)
- ▶ [Kampmann.eu/katherm-qk/calculation](http://Kampmann.eu/katherm-qk/calculation)

## Water pressure drop: heating curve

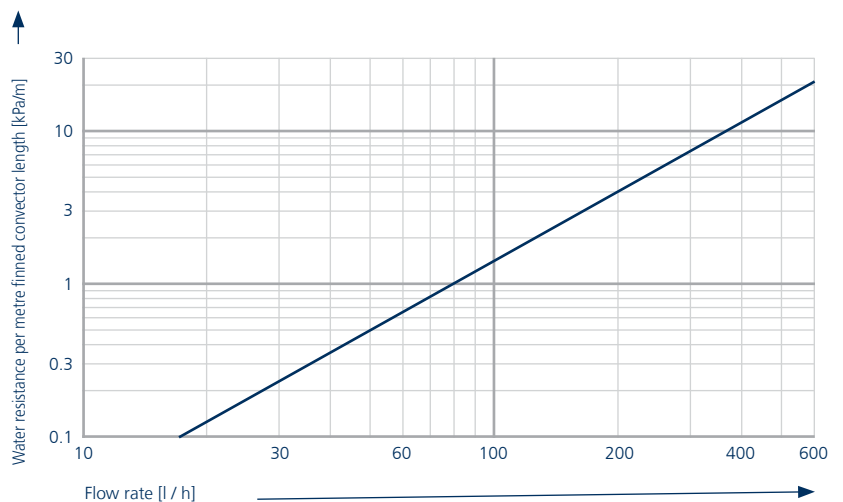

Outputs grill bar spacing 12 mm, free area approx. 70%<sup>5)</sup>



| Fan stage                    | at speed setting | Heat outputs <sup>1)</sup> |                    | Power consumption <sup>2), 6)</sup> | Current consumption <sup>6)</sup> | Air volume          | Sound pressure level <sup>3)</sup> | Sound power level  |
|------------------------------|------------------|----------------------------|--------------------|-------------------------------------|-----------------------------------|---------------------|------------------------------------|--------------------|
|                              |                  | at LPHW 75 / 65 °C         | at LPHW 82 / 71 °C |                                     |                                   |                     |                                    |                    |
|                              | [%]              | Q <sub>N</sub> [W]         | Q [W]              | P [W]                               | I [mA]                            | [m <sup>3</sup> /h] | [dB(A)]                            | [dB(A)]            |
| <b>Trench length 1000 mm</b> |                  |                            |                    |                                     |                                   |                     |                                    |                    |
| <b>Boost stage</b>           | 100              | 917                        | 1041               | 6.3                                 | 76                                | 91                  | 26                                 | 34                 |
| <b>Design levels</b>         | 80               | 809                        | 916                | 5.2                                 | 68                                | 86                  | 22                                 | 30                 |
|                              | 60               | 688                        | 777                | 4.5                                 | 61                                | 70                  | < 20 <sup>4)</sup>                 | < 28 <sup>4)</sup> |
|                              | 40               | 559                        | 631                | 4.1                                 | 58                                | 52                  | < 20 <sup>4)</sup>                 | < 28 <sup>4)</sup> |
| <b>Minimum stage</b>         | 20               | 437                        | 496                | 3.6                                 | 54                                | 43                  | < 20 <sup>4)</sup>                 | < 28 <sup>4)</sup> |
| <b>Natural convection</b>    |                  | 71                         | 84                 | ---                                 | ---                               | ---                 | ---                                | ---                |
| <b>Trench length 1200 mm</b> |                  |                            |                    |                                     |                                   |                     |                                    |                    |
| <b>Boost stage</b>           | 100              | 1419                       | 1609               | 7.7                                 | 86                                | 137                 | 29                                 | 37                 |
| <b>Design levels</b>         | 80               | 1252                       | 1417               | 6.1                                 | 73                                | 129                 | 25                                 | 33                 |
|                              | 60               | 1064                       | 1202               | 5.2                                 | 67                                | 105                 | 21                                 | 29                 |
|                              | 40               | 864                        | 976                | 4.5                                 | 62                                | 78                  | < 20 <sup>4)</sup>                 | < 28 <sup>4)</sup> |
| <b>Minimum stage</b>         | 20               | 676                        | 768                | 3.8                                 | 56                                | 65                  | < 20 <sup>4)</sup>                 | < 28 <sup>4)</sup> |
| <b>Natural convection</b>    |                  | 109                        | 130                | ---                                 | ---                               | ---                 | ---                                | ---                |
| <b>Trench length 1400 mm</b> |                  |                            |                    |                                     |                                   |                     |                                    |                    |
| <b>Boost stage</b>           | 100              | 1845                       | 2093               | 9.2                                 | 97                                | 183                 | 31                                 | 39                 |
| <b>Design levels</b>         | 80               | 1628                       | 1843               | 7.4                                 | 84                                | 172                 | 28                                 | 36                 |
|                              | 60               | 1385                       | 1564               | 6.0                                 | 72                                | 139                 | 23                                 | 31                 |
|                              | 40               | 1124                       | 1269               | 4.8                                 | 64                                | 104                 | < 20 <sup>4)</sup>                 | < 28 <sup>4)</sup> |
| <b>Minimum stage</b>         | 20               | 879                        | 998                | 4.2                                 | 58                                | 87                  | < 20 <sup>4)</sup>                 | < 28 <sup>4)</sup> |
| <b>Natural convection</b>    |                  | 142                        | 169                | ---                                 | ---                               | ---                 | ---                                | ---                |
| <b>Trench length 1600 mm</b> |                  |                            |                    |                                     |                                   |                     |                                    |                    |
| <b>Boost stage</b>           | 100              | 2347                       | 2662               | 10.9                                | 114                               | 228                 | 33                                 | 41                 |
| <b>Design levels</b>         | 80               | 2070                       | 2344               | 8.6                                 | 95                                | 215                 | 30                                 | 38                 |
|                              | 60               | 1761                       | 1988               | 6.7                                 | 79                                | 174                 | 25                                 | 33                 |
|                              | 40               | 1429                       | 1614               | 5.2                                 | 67                                | 130                 | < 20 <sup>4)</sup>                 | < 28 <sup>4)</sup> |
| <b>Minimum stage</b>         | 20               | 1118                       | 1270               | 4.4                                 | 60                                | 108                 | < 20 <sup>4)</sup>                 | < 28 <sup>4)</sup> |
| <b>Natural convection</b>    |                  | 181                        | 215                | ---                                 | ---                               | ---                 | ---                                | ---                |

Q<sub>N</sub> [W] = Standard heat output  
 Q [W] = Heat output

more »

1) At room temperature t<sub>L</sub> = 20 °C  
 2) Add an additional power consumption of 1 W per valve drive type 146906.  
 3) The sound pressure levels were calculated with an assumed room insulation of 8 dB(A). This corresponds to a clearance of 2 m, a room volume of 100 m<sup>3</sup> and a reverberation time of 0.5 s (according to VDI 2081).  
 4) Sound pressure level < 20 dB (A) and sound power level < 28 dB (A) outside the usual measuring and audible range.  
 5) Heat outputs for bar spacing 9 mm (aluminium anodised, brass) and 10.5 mm (stainless steel); free area approx. 65% can be obtained from the calculation program.  
 6) For power and current consumption for 24 V refer to the table showing control technology for 24 V electromechanical model.

# Katherm QK 190

## Outputs grille bar spacing 12 mm, free area approx. 70%<sup>5)</sup>



| Fan stage                    | at speed setting | Heat outputs <sup>1)</sup> |                    | Power consumption <sup>2), 6)</sup> | Current consumption <sup>6)</sup> | Air volume          | Sound pressure level <sup>3)</sup> | Sound power level  |
|------------------------------|------------------|----------------------------|--------------------|-------------------------------------|-----------------------------------|---------------------|------------------------------------|--------------------|
|                              |                  | at LPHW 75 / 65 °C         | at LPHW 82 / 71 °C |                                     |                                   |                     |                                    |                    |
|                              | [%]              | Q <sub>N</sub> [W]         | Q [W]              | P [W]                               | I [mA]                            | [m <sup>3</sup> /h] | [dB(A)]                            | [dB(A)]            |
| <b>Trench length 1800 mm</b> |                  |                            |                    |                                     |                                   |                     |                                    |                    |
| <b>Boost stage</b>           | 100              | 2773                       | 3146               | 11.5                                | 114                               | 274                 | 35                                 | 43                 |
| <b>Design levels</b>         | 80               | 2447                       | 2770               | 8.7                                 | 95                                | 258                 | 31                                 | 39                 |
|                              | 60               | 2081                       | 2350               | 6.8                                 | 84                                | 209                 | 26                                 | 34                 |
|                              | 40               | 1689                       | 1908               | 5.4                                 | 74                                | 156                 | 21                                 | 29                 |
| <b>Minimum stage</b>         | 20               | 1322                       | 1500               | 4.5                                 | 65                                | 130                 | < 20 <sup>4)</sup>                 | < 28 <sup>4)</sup> |
| <b>Natural convection</b>    |                  | 214                        | 254                | ---                                 | ---                               | ---                 | ---                                | ---                |
| <b>Trench length 2000 mm</b> |                  |                            |                    |                                     |                                   |                     |                                    |                    |
| <b>Boost stage</b>           | 100              | 2773                       | 3146               | 11.5                                | 114                               | 274                 | 35                                 | 43                 |
| <b>Design levels</b>         | 80               | 2447                       | 2770               | 8.7                                 | 95                                | 258                 | 31                                 | 39                 |
|                              | 60               | 2081                       | 2350               | 6.8                                 | 84                                | 209                 | 26                                 | 34                 |
|                              | 40               | 1689                       | 1908               | 5.4                                 | 74                                | 156                 | 21                                 | 29                 |
| <b>Minimum stage</b>         | 20               | 1322                       | 1500               | 4.5                                 | 65                                | 130                 | < 20 <sup>4)</sup>                 | < 28 <sup>4)</sup> |
| <b>Natural convection</b>    |                  | 214                        | 254                | ---                                 | ---                               | ---                 | ---                                | ---                |
| <b>Trench length 2200 mm</b> |                  |                            |                    |                                     |                                   |                     |                                    |                    |
| <b>Boost stage</b>           | 100              | 3498                       | 3969               | 12.1                                | 114                               | 320                 | 36                                 | 44                 |
| <b>Design levels</b>         | 80               | 3087                       | 3494               | 8.8                                 | 96                                | 301                 | 32                                 | 40                 |
|                              | 60               | 2625                       | 2964               | 7.8                                 | 84                                | 244                 | 28                                 | 36                 |
|                              | 40               | 2131                       | 2407               | 7.0                                 | 75                                | 182                 | 22                                 | 30                 |
| <b>Minimum stage</b>         | 20               | 1667                       | 1893               | 6.1                                 | 68                                | 152                 | < 20 <sup>4)</sup>                 | < 28 <sup>4)</sup> |
| <b>Natural convection</b>    |                  | 269                        | 321                | ---                                 | ---                               | ---                 | ---                                | ---                |
| <b>Trench length 2400 mm</b> |                  |                            |                    |                                     |                                   |                     |                                    |                    |
| <b>Boost stage</b>           | 100              | 3925                       | 4453               | 13.6                                | 117                               | 365                 | 37                                 | 45                 |
| <b>Design levels</b>         | 80               | 3463                       | 3920               | 10.5                                | 97                                | 344                 | 33                                 | 41                 |
|                              | 60               | 2945                       | 3326               | 8.3                                 | 85                                | 279                 | 29                                 | 37                 |
|                              | 40               | 2391                       | 2700               | 7.3                                 | 75                                | 208                 | 23                                 | 31                 |
| <b>Minimum stage</b>         | 20               | 1871                       | 2124               | 6.3                                 | 68                                | 173                 | < 20 <sup>4)</sup>                 | < 28 <sup>4)</sup> |
| <b>Natural convection</b>    |                  | 302                        | 360                | ---                                 | ---                               | ---                 | ---                                | ---                |

Q<sub>N</sub> [W] = Standard heat output

Q [W] = Heat output

more »

<sup>1)</sup> At room temperature t<sub>l</sub> = 20 °C

<sup>2)</sup> Add an additional power consumption of 1 W per valve drive type 146906.

<sup>3)</sup> The sound pressure levels were calculated with an assumed room insulation of 8 dB(A). This corresponds to a clearance of 2 m, a room volume of 100 m<sup>3</sup> and a reverberation time of 0.5 s (according to VDI 2081).

<sup>4)</sup> Sound pressure level < 20 dB (A) and sound power level < 28 dB (A) outside the usual measuring and audible range.

<sup>5)</sup> Heat outputs for bar spacing 9 mm (aluminium anodised, brass) and 10.5 mm (stainless steel); free area approx. 65% can be obtained from the calculation program.

<sup>6)</sup> For power and current consumption for 24 V refer to the table showing control technology for 24 V electromechanical model.

**Outputs grille bar spacing 12 mm, free area approx. 70%<sup>5)</sup>**



| Fan stage                    | at speed setting<br>[%] | Heat outputs <sup>1)</sup> |                       | Power consumption <sup>2), 6)</sup><br>P<br>[W] | Current consumption <sup>6)</sup><br>I<br>[mA] | Air volume<br>[m <sup>3</sup> /h] | Sound pressure level <sup>3)</sup><br>[dB(A)] | Sound power level<br>[dB(A)] |
|------------------------------|-------------------------|----------------------------|-----------------------|---|--|-----------------------------------|---|------------------------------|
|                              |                         | at LPHW<br>75 / 65 °C      | at LPHW<br>82 / 71 °C |   |  |                                   |   |                              |
|                              |                         | Q <sub>N</sub><br>[W]      | Q<br>[W]              |   |  |                                   |   |                              |
| <b>Trench length 2600 mm</b> |                         |                            |                       |   |  |                                   |   |                              |
| <b>Boost stage</b>           | 100                     | 4426                       | 5021                  | 15.0  | 128  | 411                               | 37  | 45                           |
| <b>Design levels</b>         | 80                      | 3906                       | 4421                  | 11.3  | 102  | 387                               | 34  | 42                           |
|                              | 60                      | 3321                       | 3751                  | 8.8   | 86   | 314                               | 30  | 38                           |
|                              | 40                      | 2696                       | 3045                  | 7.5   | 76   | 234                               | 24  | 32                           |
| <b>Minimum stage</b>         | 20                      | 2109                       | 2395                  | 6.5   | 71   | 195                               | 20  | 28                           |
| <b>Natural convection</b>    |                         | 341                        | 406                   | ---   | ---  | ---                               | ---   | ---                          |
| <b>Trench length 2800 mm</b> |                         |                            |                       |   |  |                                   |   |                              |
| <b>Boost stage</b>           | 100                     | 4853                       | 5505                  | 17.4  | 146  | 457                               | 39  | 47                           |
| <b>Design levels</b>         | 80                      | 4282                       | 4847                  | 12.9  | 116  | 430                               | 35  | 43                           |
|                              | 60                      | 3641                       | 4112                  | 9.9   | 95   | 348                               | 31  | 39                           |
|                              | 40                      | 2956                       | 3339                  | 7.7   | 79   | 260                               | 25  | 33                           |
| <b>Minimum stage</b>         | 20                      | 2313                       | 2626                  | 6.6   | 73   | 217                               | 21  | 29                           |
| <b>Natural convection</b>    |                         | 374                        | 445                   | ---   | ---  | ---                               | ---   | ---                          |
| <b>Trench length 3000 mm</b> |                         |                            |                       |   |  |                                   |   |                              |
| <b>Boost stage</b>           | 100                     | 5354                       | 6074                  | 19.4  | 159  | 502                               | 40  | 48                           |
| <b>Design levels</b>         | 80                      | 4725                       | 5348                  | 13.8  | 121  | 473                               | 36  | 44                           |
|                              | 60                      | 4018                       | 4537                  | 10.5  | 97   | 383                               | 32  | 40                           |
|                              | 40                      | 3261                       | 3684                  | 8.0   | 81   | 286                               | 26  | 34                           |
| <b>Minimum stage</b>         | 20                      | 2552                       | 2897                  | 6.7   | 73   | 238                               | 22  | 30                           |
| <b>Natural convection</b>    |                         | 412                        | 491                   | ---   | ---  | ---                               | ---   | ---                          |
| <b>Trench length 3200 mm</b> |                         |                            |                       |   |  |                                   |   |                              |
| <b>Boost stage</b>           | 100                     | 5781                       | 6558                  | 21.1  | 173  | 548                               | 41  | 49                           |
| <b>Design levels</b>         | 80                      | 5101                       | 5774                  | 14.6  | 128  | 516                               | 37  | 45                           |
|                              | 60                      | 4338                       | 4898                  | 10.8  | 101  | 418                               | 32  | 40                           |
|                              | 40                      | 3521                       | 3977                  | 8.2   | 83   | 312                               | 27  | 35                           |
| <b>Minimum stage</b>         | 20                      | 2755                       | 3128                  | 6.8   | 74   | 260                               | 22  | 30                           |
| <b>Natural convection</b>    |                         | 445                        | 530                   | ---   | ---  | ---                               | ---   | ---                          |

Q<sub>N</sub> [W] = Standard heat output  
Q [W] = Heat output

1) At room temperature t<sub>L</sub> = 20 °C  
 2) Add an additional power consumption of 1 W per valve drive type 146906.  
 3) The sound pressure levels were calculated with an assumed room insulation of 8 dB(A). This corresponds to a clearance of 2 m, a room volume of 100 m<sup>3</sup> and a reverberation time of 0.5 s (according to VDI 2081).  
 4) Sound pressure level < 20 dB (A) and sound power level < 28 dB (A) outside the usual measuring and audible range.  
 5) Heat outputs for bar spacing 9 mm (aluminium anodised, brass) and 10.5 mm (stainless steel); free area approx. 65% can be obtained from the calculation program.  
 6) For power and current consumption for 24 V refer to the table showing control technology for 24 V electromechanical model.

# Katherm QK 215

Technical drawings (all dimensions in mm)

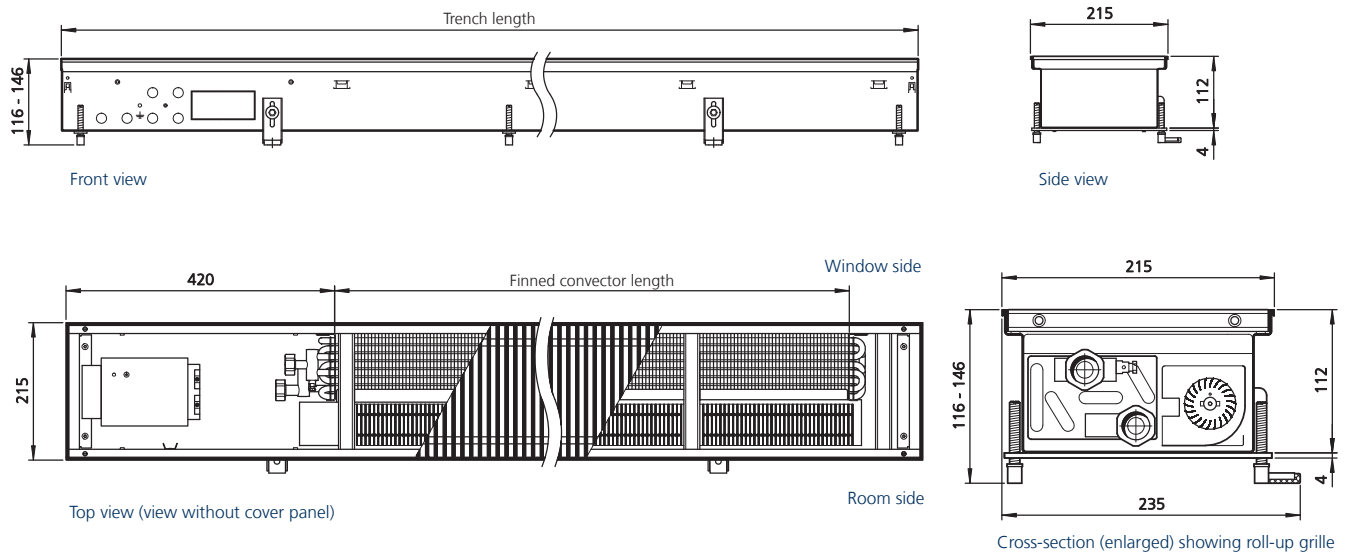

| Trench length | Finned convector length |
|---------------|-------------------------|
| [mm]          | [mm]                    |
| 1000          | 430                     |
| 1200          | 665                     |
| 1400          | 865                     |
| 1600          | 1100                    |
| 1800          | 1300                    |
| 2000          | 1300                    |

| Trench length | Finned convector length |
|---------------|-------------------------|
| [mm]          | [mm]                    |
| 2200          | 1640                    |
| 2400          | 1840                    |
| 2600          | 2075                    |
| 2800          | 2275                    |
| 3000          | 2510                    |
| 3200          | 2710                    |

## Specifications

### Connections, female thread:

Eurokonus, same end, connections on left

Make use of our online calculation programs to calculate your heat outputs and flow rates with a couple of clicks!

- ▶ [Kampmann.co.uk/katherm-qk/calculation](http://Kampmann.co.uk/katherm-qk/calculation)
- ▶ [Kampmann.eu/katherm-qk/calculation](http://Kampmann.eu/katherm-qk/calculation)

## Water pressure drop: heating curve

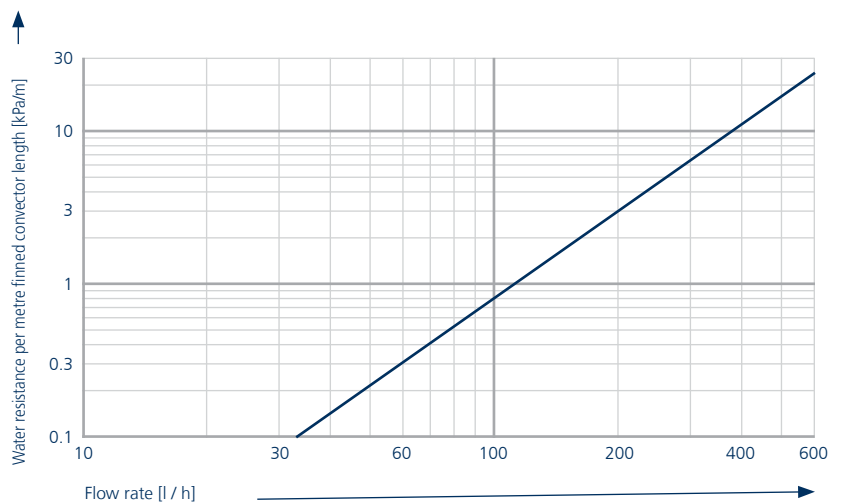

Outputs grille bar spacing 12 mm, free area approx. 70%<sup>5)</sup>



| Fan stage                    | at speed setting | Heat outputs <sup>1)</sup> |                    | Power consumption <sup>2), 6)</sup> | Current consumption <sup>6)</sup> | Air volume          | Sound pressure level <sup>3)</sup> | Sound power level  |
|------------------------------|------------------|----------------------------|--------------------|-------------------------------------|-----------------------------------|---------------------|------------------------------------|--------------------|
|                              |                  | at LPHW 75 / 65 °C         | at LPHW 82 / 71 °C |                                     |                                   |                     |                                    |                    |
|                              | [%]              | Q <sub>N</sub> [W]         | Q [W]              | P [W]                               | I [mA]                            | [m <sup>3</sup> /h] | [dB(A)]                            | [dB(A)]            |
| <b>Trench length 1000 mm</b> |                  |                            |                    |                                     |                                   |                     |                                    |                    |
| <b>Boost stage</b>           | 100              | 956                        | 1090               | 6.3                                 | 76                                | 91                  | 26                                 | 34                 |
| <b>Design levels</b>         | 80               | 874                        | 993                | 5.2                                 | 68                                | 86                  | 22                                 | 30                 |
|                              | 60               | 786                        | 893                | 4.5                                 | 61                                | 70                  | < 20 <sup>4)</sup>                 | < 28 <sup>4)</sup> |
|                              | 40               | 666                        | 753                | 4.1                                 | 58                                | 52                  | < 20 <sup>4)</sup>                 | < 28 <sup>4)</sup> |
| <b>Minimum stage</b>         | 20               | 522                        | 589                | 3.6                                 | 54                                | 43                  | < 20 <sup>4)</sup>                 | < 28 <sup>4)</sup> |
| <b>Natural convection</b>    |                  | 87                         | 105                | ---                                 | ---                               | ---                 | ---                                | ---                |
| <b>Trench length 1200 mm</b> |                  |                            |                    |                                     |                                   |                     |                                    |                    |
| <b>Boost stage</b>           | 100              | 1478                       | 1686               | 7.7                                 | 86                                | 137                 | 29                                 | 37                 |
| <b>Design levels</b>         | 80               | 1352                       | 1536               | 6.1                                 | 73                                | 129                 | 25                                 | 33                 |
|                              | 60               | 1215                       | 1382               | 5.2                                 | 67                                | 105                 | 21                                 | 29                 |
|                              | 40               | 1030                       | 1165               | 4.5                                 | 62                                | 78                  | < 20 <sup>4)</sup>                 | < 28 <sup>4)</sup> |
| <b>Minimum stage</b>         | 20               | 807                        | 911                | 3.8                                 | 56                                | 65                  | < 20 <sup>4)</sup>                 | < 28 <sup>4)</sup> |
| <b>Natural convection</b>    |                  | 134                        | 162                | ---                                 | ---                               | ---                 | ---                                | ---                |
| <b>Trench length 1400 mm</b> |                  |                            |                    |                                     |                                   |                     |                                    |                    |
| <b>Boost stage</b>           | 100              | 1923                       | 2193               | 9.2                                 | 97                                | 183                 | 31                                 | 39                 |
| <b>Design levels</b>         | 80               | 1758                       | 1997               | 7.4                                 | 84                                | 172                 | 28                                 | 36                 |
|                              | 60               | 1581                       | 1797               | 6.0                                 | 72                                | 139                 | 23                                 | 31                 |
|                              | 40               | 1340                       | 1516               | 4.8                                 | 64                                | 104                 | < 20 <sup>4)</sup>                 | < 28 <sup>4)</sup> |
| <b>Minimum stage</b>         | 20               | 1050                       | 1185               | 4.2                                 | 58                                | 87                  | < 20 <sup>4)</sup>                 | < 28 <sup>4)</sup> |
| <b>Natural convection</b>    |                  | 175                        | 211                | ---                                 | ---                               | ---                 | ---                                | ---                |
| <b>Trench length 1600 mm</b> |                  |                            |                    |                                     |                                   |                     |                                    |                    |
| <b>Boost stage</b>           | 100              | 2445                       | 2789               | 10.9                                | 114                               | 228                 | 33                                 | 41                 |
| <b>Design levels</b>         | 80               | 2236                       | 2540               | 8.6                                 | 95                                | 215                 | 30                                 | 38                 |
|                              | 60               | 2010                       | 2285               | 6.7                                 | 79                                | 174                 | 25                                 | 33                 |
|                              | 40               | 1704                       | 1927               | 5.2                                 | 67                                | 130                 | < 20 <sup>4)</sup>                 | < 28 <sup>4)</sup> |
| <b>Minimum stage</b>         | 20               | 1335                       | 1507               | 4.4                                 | 60                                | 108                 | < 20 <sup>4)</sup>                 | < 28 <sup>4)</sup> |
| <b>Natural convection</b>    |                  | 222                        | 268                | ---                                 | ---                               | ---                 | ---                                | ---                |

Q<sub>N</sub> [W] = Standard heat output  
 Q [W] = Heat output

[more »](#)

1) At room temperature t<sub>L</sub> = 20 °C  
 2) Add an additional power consumption of 1 W per valve drive type 146906.  
 3) The sound pressure levels were calculated with an assumed room insulation of 8 dB(A). This corresponds to a clearance of 2 m, a room volume of 100 m<sup>3</sup> and a reverberation time of 0.5 s (according to VDI 2081).  
 4) Sound pressure level < 20 dB (A) and sound power level < 28 dB (A) outside the usual measuring and audible range.  
 5) Heat outputs for bar spacing 9 mm (aluminium anodised, brass) and 10.5 mm (stainless steel); free area approx. 65% can be obtained from the calculation program.  
 6) For power and current consumption for 24 V refer to the table showing control technology for 24 V electromechanical model.

# Katherm QK 215

## Outputs grille bar spacing 12 mm, free area approx. 70%<sup>5)</sup>



| Fan stage                    | at speed setting | Heat outputs <sup>1)</sup> |                    | Power consumption <sup>2), 6)</sup> | Current consumption <sup>6)</sup> | Air volume          | Sound pressure level <sup>3)</sup> | Sound power level  |
|------------------------------|------------------|----------------------------|--------------------|-------------------------------------|-----------------------------------|---------------------|------------------------------------|--------------------|
|                              |                  | at LPHW 75 / 65 °C         | at LPHW 82 / 71 °C |                                     |                                   |                     |                                    |                    |
|                              | [%]              | Q <sub>N</sub> [W]         | Q [W]              | P [W]                               | I [mA]                            | [m <sup>3</sup> /h] | [dB(A)]                            | [dB(A)]            |
| <b>Trench length 1800 mm</b> |                  |                            |                    |                                     |                                   |                     |                                    |                    |
| <b>Boost stage</b>           | 100              | 2890                       | 3296               | 11.5                                | 114                               | 274                 | 35                                 | 43                 |
| <b>Design levels</b>         | 80               | 2642                       | 3002               | 8.7                                 | 95                                | 258                 | 31                                 | 39                 |
|                              | 60               | 2376                       | 2701               | 6.8                                 | 84                                | 209                 | 26                                 | 34                 |
|                              | 40               | 2014                       | 2278               | 5.4                                 | 74                                | 156                 | 21                                 | 29                 |
| <b>Minimum stage</b>         | 20               | 1578                       | 1780               | 4.5                                 | 65                                | 130                 | < 20 <sup>4)</sup>                 | < 28 <sup>4)</sup> |
| <b>Natural convection</b>    |                  | 262                        | 316                | ---                                 | ---                               | ---                 | ---                                | ---                |
| <b>Trench length 2000 mm</b> |                  |                            |                    |                                     |                                   |                     |                                    |                    |
| <b>Boost stage</b>           | 100              | 2890                       | 3296               | 11.5                                | 114                               | 274                 | 35                                 | 43                 |
| <b>Design levels</b>         | 80               | 2642                       | 3002               | 8.7                                 | 95                                | 258                 | 31                                 | 39                 |
|                              | 60               | 2376                       | 2701               | 6.8                                 | 84                                | 209                 | 26                                 | 34                 |
|                              | 40               | 2014                       | 2278               | 5.4                                 | 74                                | 156                 | 21                                 | 29                 |
| <b>Minimum stage</b>         | 20               | 1578                       | 1780               | 4.5                                 | 65                                | 130                 | < 20 <sup>4)</sup>                 | < 28 <sup>4)</sup> |
| <b>Natural convection</b>    |                  | 262                        | 316                | ---                                 | ---                               | ---                 | ---                                | ---                |
| <b>Trench length 2200 mm</b> |                  |                            |                    |                                     |                                   |                     |                                    |                    |
| <b>Boost stage</b>           | 100              | 3646                       | 4157               | 12.1                                | 114                               | 320                 | 36                                 | 44                 |
| <b>Design levels</b>         | 80               | 3333                       | 3787               | 8.8                                 | 96                                | 301                 | 32                                 | 40                 |
|                              | 60               | 2997                       | 3407               | 7.8                                 | 84                                | 244                 | 28                                 | 36                 |
|                              | 40               | 2541                       | 2873               | 7.0                                 | 75                                | 182                 | 22                                 | 30                 |
| <b>Minimum stage</b>         | 20               | 1991                       | 2246               | 6.1                                 | 68                                | 152                 | < 20 <sup>4)</sup>                 | < 28 <sup>4)</sup> |
| <b>Natural convection</b>    |                  | 331                        | 399                | ---                                 | ---                               | ---                 | ---                                | ---                |
| <b>Trench length 2400 mm</b> |                  |                            |                    |                                     |                                   |                     |                                    |                    |
| <b>Boost stage</b>           | 100              | 4091                       | 4664               | 13.6                                | 117                               | 365                 | 37                                 | 45                 |
| <b>Design levels</b>         | 80               | 3740                       | 4249               | 10.5                                | 97                                | 344                 | 33                                 | 41                 |
|                              | 60               | 3362                       | 3823               | 8.3                                 | 85                                | 279                 | 29                                 | 37                 |
|                              | 40               | 2851                       | 3224               | 7.3                                 | 75                                | 208                 | 23                                 | 31                 |
| <b>Minimum stage</b>         | 20               | 2233                       | 2520               | 6.3                                 | 68                                | 173                 | < 20 <sup>4)</sup>                 | < 28 <sup>4)</sup> |
| <b>Natural convection</b>    |                  | 371                        | 448                | ---                                 | ---                               | ---                 | ---                                | ---                |

Q<sub>N</sub> [W] = Standard heat output  
Q [W] = Heat output

more »

<sup>1)</sup> At room temperature t<sub>l</sub> = 20 °C

<sup>2)</sup> Add an additional power consumption of 1 W per valve drive type 146906.

<sup>3)</sup> The sound pressure levels were calculated with an assumed room insulation of 8 dB(A). This corresponds to a clearance of 2 m, a room volume of 100 m<sup>3</sup> and a reverberation time of 0.5 s (according to VDI 2081).

<sup>4)</sup> Sound pressure level < 20 dB (A) and sound power level < 28 dB (A) outside the usual measuring and audible range.

<sup>5)</sup> Heat outputs for bar spacing 9 mm (aluminium anodised, brass) and 10.5 mm (stainless steel); free area approx. 65% can be obtained from the calculation program.

<sup>6)</sup> For power and current consumption for 24 V refer to the table showing control technology for 24 V electromechanical model.



Outputs grille bar spacing 12 mm, free area approx. 70%<sup>5)</sup>

| Fan stage                    | at speed setting | Heat outputs <sup>1)</sup> |                    | Power consumption <sup>2), 6)</sup> | Current consumption <sup>6)</sup> | Air volume          | Sound pressure level <sup>3)</sup> | Sound power level |
|------------------------------|------------------|----------------------------|--------------------|-------------------------------------|-----------------------------------|---------------------|------------------------------------|-------------------|
|                              |                  | at LPHW 75 / 65 °C         | at LPHW 82 / 71 °C |                                     |                                   |                     |                                    |                   |
|                              | [%]              | Q <sub>N</sub> [W]         | Q [W]              | P [W]                               | I [mA]                            | [m <sup>3</sup> /h] | [dB(A)]                            | [dB(A)]           |
| <b>Trench length 2600 mm</b> |                  |                            |                    |                                     |                                   |                     |                                    |                   |
| <b>Boost stage</b>           | 100              | 4613                       | 5260               | 15.0                                | 128                               | 411                 | 37                                 | 45                |
| <b>Design levels</b>         | 80               | 4217                       | 4792               | 11.3                                | 102                               | 387                 | 34                                 | 42                |
|                              | 60               | 3792                       | 4311               | 8.8                                 | 86                                | 314                 | 30                                 | 38                |
|                              | 40               | 3215                       | 3636               | 7.5                                 | 76                                | 234                 | 24                                 | 32                |
| <b>Minimum stage</b>         | 20               | 2519                       | 2842               | 6.5                                 | 71                                | 195                 | 20                                 | 28                |
| <b>Natural convection</b>    |                  | 419                        | 505                | ---                                 | ---                               | ---                 | ---                                | ---               |
| <b>Trench length 2800 mm</b> |                  |                            |                    |                                     |                                   |                     |                                    |                   |
| <b>Boost stage</b>           | 100              | 5058                       | 5767               | 17.4                                | 146                               | 457                 | 39                                 | 47                |
| <b>Design levels</b>         | 80               | 4624                       | 5253               | 12.9                                | 116                               | 430                 | 35                                 | 43                |
|                              | 60               | 4157                       | 4727               | 9.9                                 | 95                                | 348                 | 31                                 | 39                |
|                              | 40               | 3525                       | 3986               | 7.7                                 | 79                                | 260                 | 25                                 | 33                |
| <b>Minimum stage</b>         | 20               | 2761                       | 3116               | 6.6                                 | 73                                | 217                 | 21                                 | 29                |
| <b>Natural convection</b>    |                  | 459                        | 554                | ---                                 | ---                               | ---                 | ---                                | ---               |
| <b>Trench length 3000 mm</b> |                  |                            |                    |                                     |                                   |                     |                                    |                   |
| <b>Boost stage</b>           | 100              | 5580                       | 6363               | 19.4                                | 159                               | 502                 | 40                                 | 48                |
| <b>Design levels</b>         | 80               | 5101                       | 5796               | 13.8                                | 121                               | 473                 | 36                                 | 44                |
|                              | 60               | 4587                       | 5215               | 10.5                                | 97                                | 383                 | 32                                 | 40                |
|                              | 40               | 3889                       | 4398               | 8.0                                 | 81                                | 286                 | 26                                 | 34                |
| <b>Minimum stage</b>         | 20               | 3047                       | 3438               | 6.7                                 | 73                                | 238                 | 22                                 | 30                |
| <b>Natural convection</b>    |                  | 506                        | 611                | ---                                 | ---                               | ---                 | ---                                | ---               |
| <b>Trench length 3200 mm</b> |                  |                            |                    |                                     |                                   |                     |                                    |                   |
| <b>Boost stage</b>           | 100              | 6025                       | 6870               | 21.1                                | 173                               | 548                 | 41                                 | 49                |
| <b>Design levels</b>         | 80               | 5508                       | 6258               | 14.6                                | 128                               | 516                 | 37                                 | 45                |
|                              | 60               | 4952                       | 5630               | 10.8                                | 101                               | 418                 | 32                                 | 40                |
|                              | 40               | 4199                       | 4748               | 8.2                                 | 83                                | 312                 | 27                                 | 35                |
| <b>Minimum stage</b>         | 20               | 3289                       | 3712               | 6.8                                 | 74                                | 260                 | 22                                 | 30                |
| <b>Natural convection</b>    |                  | 547                        | 660                | ---                                 | ---                               | ---                 | ---                                | ---               |

Q<sub>N</sub> [W] = Standard heat output

Q [W] = Heat output

<sup>1)</sup> At room temperature t<sub>L</sub> = 20 °C

<sup>2)</sup> Add an additional power consumption of 1 W per valve drive type 146906.

<sup>3)</sup> The sound pressure levels were calculated with an assumed room insulation of 8 dB(A). This corresponds to a clearance of 2 m, a room volume of 100 m<sup>3</sup> and a reverberation time of 0.5 s (according to VDI 2081).

<sup>4)</sup> Sound pressure level < 20 dB (A) and sound power level < 28 dB (A) outside the usual measuring and audible range.

<sup>5)</sup> Heat outputs for bar spacing 9 mm (aluminium anodised, brass) and 10.5 mm (stainless steel); free area approx. 65% can be obtained from the calculation program.

<sup>6)</sup> For power and current consumption for 24 V refer to the table showing control technology for 24 V electromechanical model.

# 03 ▶ Design information

---



## Information on planning and design

Katherm QK are suitable for use in all kinds of buildings demanding heating due to their internal loads.

High heating loads in the rooms can be met with ultra-quiet EC fans. Katherm QK are also used to efficiently combat condensation on external glazing.

They are generally positioned directly in front of the external façade without a large gap. Katherm QK can provide cost-effective and efficient heating, particularly in front of large areas of glazing.

### Air outlet

All Katherm QK are positioned with the convector on the window side. The warm air rising up the exterior façade flows draught-free into the room, guaranteeing optimum cold air screening.

### Acoustics

The respective sound power levels of Katherm QK are indicated in the tables (see "Technical Data"). The sound pressure levels were calculated with an assumed

room insulation of 8 dB(A). This corresponds to a distance of 2 m, a room volume of 100m<sup>3</sup> and a reverberation time of 0.5 s (in accordance with VDI 2081).

As the sound level is not only due to the Katherm QK, but is also influenced by the number of Katherm QK and also very significantly by the acoustic characteristics of the room, the actual figure may vary in practice.

We would recommend designing Katherm QK taking into account the respective permitted sound pressure level in the room.

### Heat outputs

The heat outputs were calculated based on DIN EN 16430. We would recommend our online calculation programs to convert to other operating conditions at:

[Kampmann.de/katherm-qk/calculation](http://Kampmann.de/katherm-qk/calculation)

Make use of our online calculation programs to calculate your heat outputs and flow rates with a couple of clicks!

- ▶ [Kampmann.co.uk/katherm-qk/calculation](http://Kampmann.co.uk/katherm-qk/calculation)
- ▶ [Kampmann.eu/katherm-qk/calculation](http://Kampmann.eu/katherm-qk/calculation)

# Katherm QK – supply air modules ZL

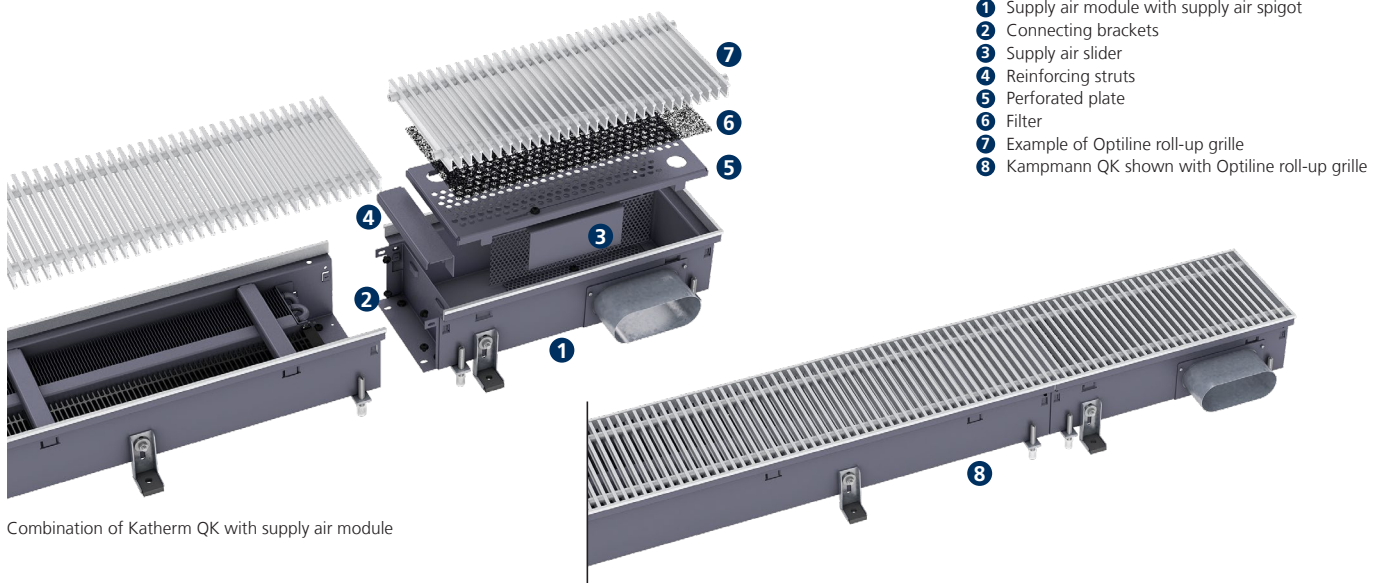

Combination of Katherm QK with supply air module

The Katherm supply air module ZL is available for all trench convectors (Katherm range). This represents a 400 mm long trench, which can be fitted to all designs of Katherm units. Treated supply air can also be fed into rooms through the Katherm supply air module ZL. This is achieved with different sizes/designs of spigots for the most diverse trench dimensions. It is possible to regulate the volumetric flow by means of slider elements in the supply air modules.

### Benefits:

- ▶ available for trench widths and heights as per the table in the Katherm range
- ▶ supply air feed through the Katherm floor trench
- ▶ low leaving air speeds, hence pleasant levels of comfort
- ▶ low sound development when correctly designed
- ▶ low investment and maintenance costs
- ▶ supply air outlets visually identical to Katherm trench heaters
- ▶ no wear parts / no electrically rotating parts

| Trench width | Trench length | Trench height | Supply air spigot | Design air volume |
|--------------|---------------|---------------|-------------------|-------------------|
| [mm]         | [mm]          | [mm]          | [mm]              | [m³/h]            |
| 190          | 400           | 112           | oval 51x128       | 70                |
| 215          | 400           | 112           | oval 51x128       | 70                |

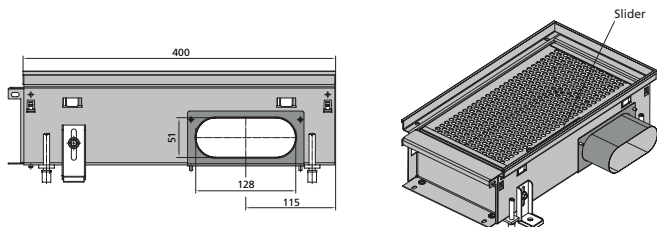

Example of 190/112

## Comfort

Comfort also plays a key role in air conditioning. We'll help you to consider this aspect when designing a project using Kampmann trench convectors, at the same time as complying with the current guidelines in DIN EN 15251 (in future DIN EN 16798 Parts 1 and 2) and DIN EN ISO 7730. Essentially the following recommended values can be assumed:

**For heating:**  
 **Supply air outlet air temperature:** 20–26 °C (but not lower than the room temperature)  
 Outlet speed: < 1.5 m/s  
 Distance of supply air trench to the occupied zone: > 0.5 m

**For cooling:**  
 **Supply air outlet air temperature:** < 4K below room temperature  
 Outlet speed: < 1.2 m/s  
 Distance of supply air trench to the occupied zone: > 1 m

### Other parameters

In individual cases, additional parameters, such as room and supply air humidity, as well as leaving air speed, need to be taken into consideration. (See DIN EN ISO 7730)

### Additional information

The supply air models Katherm ZL can be used for cooling, heating or isothermic air exchange using preconditioned primary air. A spigot or connection at the front end is also possible with appropriate trench dimensions and sufficient space in the air outlet area (examination on request!).

The upper limit of the air volume in the spigot is calculated from the maximum air speed and cross-section of the spigot. This speed should not exceed 3.0 m/s to avoid additional sound emissions. The resulting air-side pressure losses vary according to the air volume as per the diagram.

### Design diagram

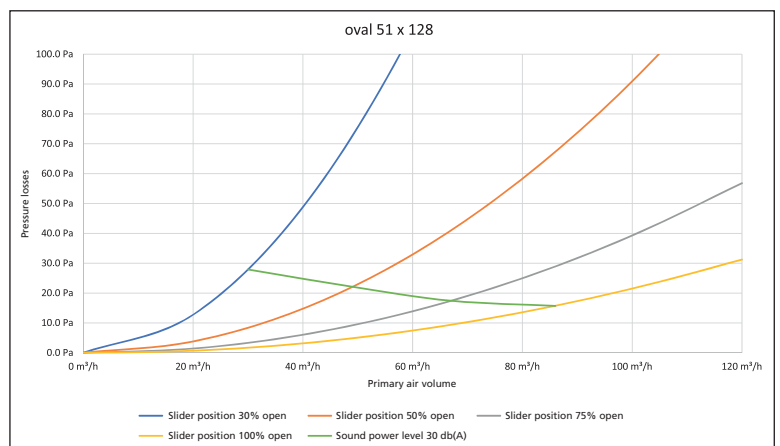

## Hydraulic set-up

The Katherm QK (24 V electromechanical, 230 V electromechanical or KaControl) offers two hydraulic design options with the optional accessory kits. Valve kit type 142110 can be used if valve control is planned in the trench heater. If the hydraulic system is to be

controlled via a central heating circuit distributor, 2 no. return shut-off valves type 145952 can be used to shut off the copper-aluminium convectors.

### Decentralised valve control

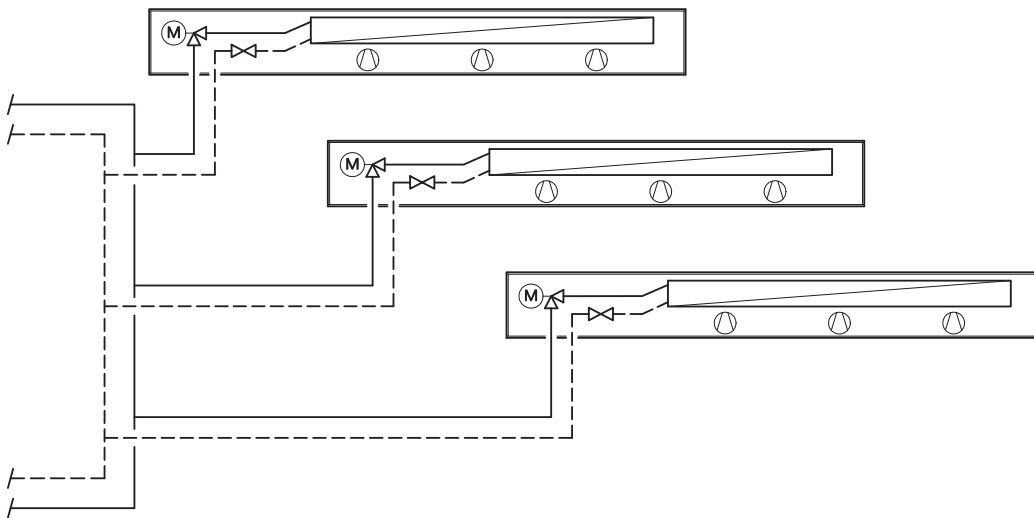

Accessories: Valve kit type 194000142110 or valve body type 194000346909, return shut-off valve type 194000145952, thermoelectric actuator type 194000146906 need to be ordered separately.

### Central heating circuit distributor

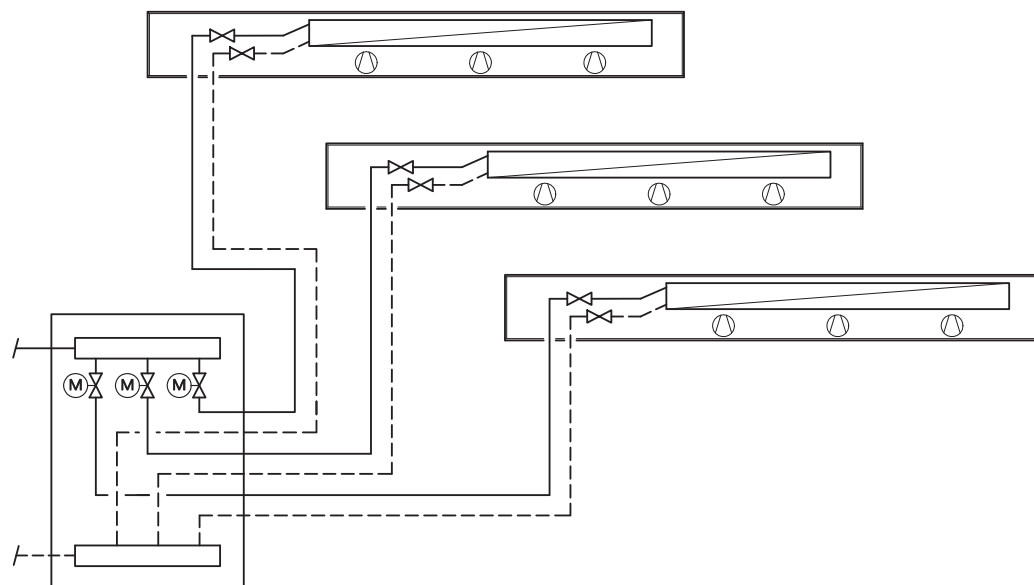

Accessories: 2 no. return shut-off valves type 194000145952 must be ordered separately.

# 04 ▶ Controls

Three different control options are available for ease of integration into individual control schemes. The 24 V version permits direct connection to on-site building management systems. An electromechanical control option using a room thermostat or alternatively the KaControl system are both available for continuously variable control with 230 V supply voltage. KaControl

represents the system solution for maximum energy efficiency, limitless integration options into building automation systems and the highest degree of user-friendly operating philosophy.

## 24 V electromechanical model

Model for complete on site control of the Katherm QK.

### Product features

- ▶ The operating voltage must be provided by a central on-site 24 V DC voltage supply.
- ▶ The external voltage supply results in a space-saving connection area within the trench.
- ▶ Kampmann offers a range of switching power units in different output classes as accessories for the voltage supply (24 V DC).
- ▶ The fan automatically switches off in the event of a motor fault.

Table with rating values

| Trench length [mm] | QK 190 / QK 215<br>Power consumption P [W]<br>Current consumption I [mA]<br>at fan speed |        |       |        |       |        |       |        |       |        |
|--------------------|--|--------|-------|--------|-------|--------|-------|--------|-------|--------|
|                    | 20%  |        | 40%   |        | 60%   |        | 80%   |        | 100%  |        |
|                    | P [W]  | I [mA] | P [W] | I [mA] | P [W] | I [mA] | P [W] | I [mA] | P [W] | I [mA] |
| 1000               | 2.6  | 39     | 3.1   | 44     | 3.5   | 47     | 4.2   | 55     | 5.3   | 64     |
| 1200               | 2.8  | 41     | 3.5   | 48     | 4.2   | 54     | 5.1   | 61     | 6.7   | 75     |
| 1400               | 3.2  | 44     | 3.8   | 51     | 5.0   | 60     | 6.4   | 73     | 8.2   | 86     |
| 1600               | 3.4  | 46     | 4.2   | 54     | 5.7   | 67     | 7.6   | 84     | 9.9   | 104    |
| 1800               | 3.5  | 51     | 4.4   | 59     | 5.8   | 70     | 7.7   | 85     | 10.5  | 104    |
| 2000               | 3.5  | 51     | 4.4   | 59     | 5.8   | 70     | 7.7   | 85     | 10.5  | 104    |
| 2200               | 5.1  | 57     | 6.0   | 64     | 6.8   | 71     | 7.8   | 86     | 11.1  | 105    |
| 2400               | 5.3  | 57     | 6.3   | 65     | 7.3   | 72     | 9.5   | 88     | 12.6  | 108    |
| 2600               | 5.5  | 60     | 6.5   | 66     | 7.8   | 76     | 10.3  | 93     | 14.0  | 119    |
| 2800               | 5.6  | 62     | 6.7   | 69     | 8.9   | 85     | 11.9  | 107    | 16.4  | 138    |
| 3000               | 5.7  | 62     | 7.0   | 71     | 9.5   | 88     | 12.8  | 112    | 18.4  | 151    |
| 3200               | 5.8  | 63     | 7.2   | 73     | 9.8   | 92     | 13.6  | 119    | 20.1  | 165    |

The power and current consumption of the actuators (1 W) is not taken into account.

## Electrical cabling – BMS control

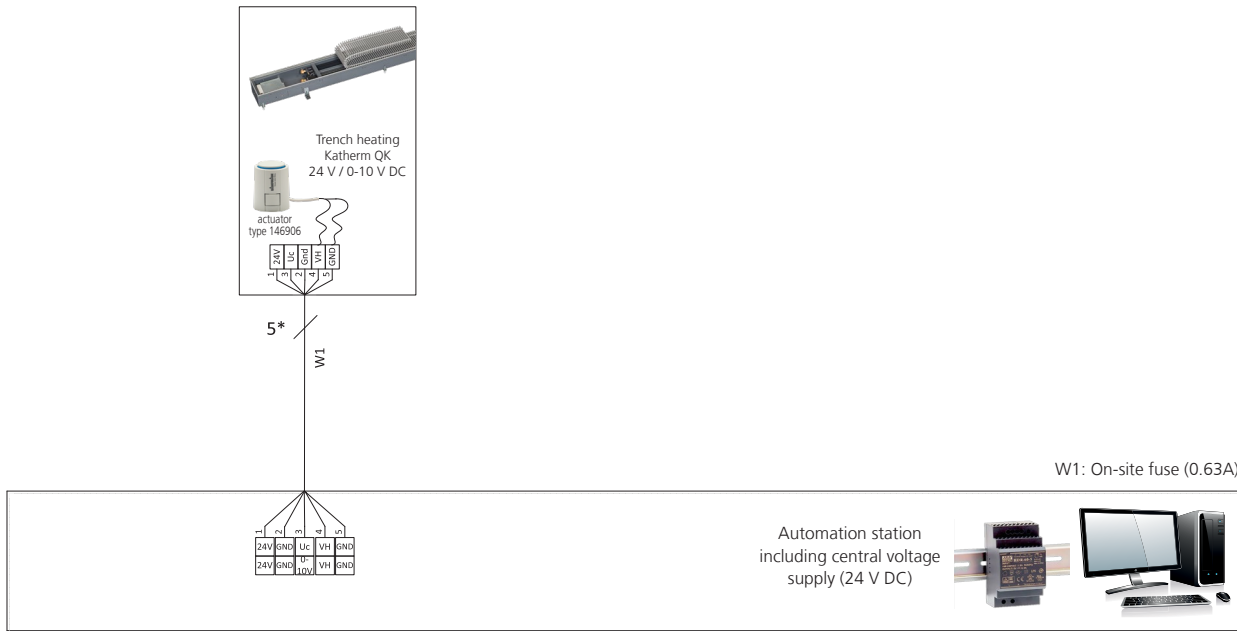

\* Lay shielded cables (e.g. IY(ST)Y, 0.8 mm), separately from high-voltage cables.  
 W1: Voltage supply and control signal for (on-site fuse 0.63 A) and actuator.  
 Subject to technical modifications: Refer to the control accessory documentation in the event of deviation from the circuit diagrams!

## Electrical cabling – control via clock thermostat, type 30456

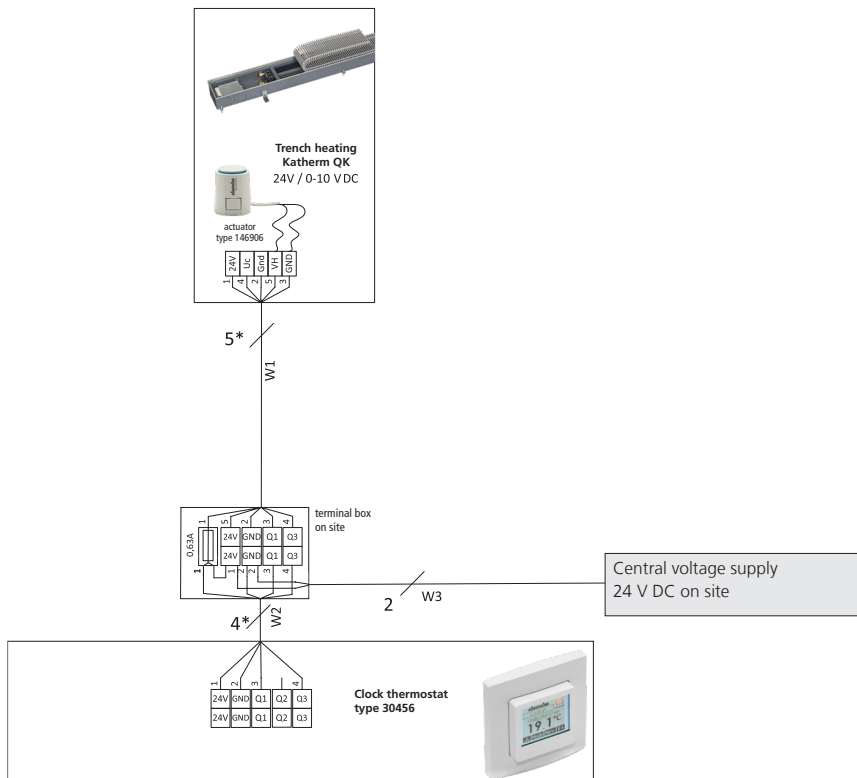

\* Lay shielded cables (e.g. IY(ST)Y, 0.8 mm), separately from high-voltage cables.  
 W1: Voltage supply and control signal for fan (on-site fuse 0.63 A) and actuator.  
 W2: Voltage supply and control signal for fan and actuator.  
 W3: Voltage supply (fuse by others).



# 230 V electromechanical model

Design for on-site control or for room regulation with intuitive operation of the trench convectors.

- ▶ In the event of a motor fault, the fan automatically switches off and a fault signal is issued at a potential-free contact.
- ▶ Kampmann offers an extensive range of control accessories for all required functions.

### Product features

- ▶ The Katherm QK features an integral switch power supply to connect to the 230 V AC voltage supply.

### Table with rating values

| Trench length [mm] | QK 190 / QK 215<br>Power consumption P [W]<br>Current consumption I [mA]<br>at fan speed |        |       |        |       |        |       |        |       |        |
|--------------------|--|--------|-------|--------|-------|--------|-------|--------|-------|--------|
|                    | 20%  |        | 40%   |        | 60%   |        | 80%   |        | 100%  |        |
|                    | P [W]  | I [mA] | P [W] | I [mA] | P [W] | I [mA] | P [W] | I [mA] | P [W] | I [mA] |
| 1000               | 3.6  | 54     | 4.1   | 58     | 4.5   | 61     | 5.2   | 68     | 6.3   | 76     |
| 1200               | 3.8  | 56     | 4.5   | 62     | 5.2   | 67     | 6.1   | 73     | 7.7   | 86     |
| 1400               | 4.2  | 58     | 4.8   | 64     | 6.0   | 72     | 7.4   | 84     | 9.2   | 97     |
| 1600               | 4.4  | 60     | 5.2   | 67     | 6.7   | 79     | 8.6   | 95     | 10.9  | 114    |
| 1800               | 4.5  | 65     | 5.4   | 74     | 6.8   | 84     | 8.7   | 95     | 11.5  | 114    |
| 2000               | 4.5  | 65     | 5.4   | 74     | 6.8   | 84     | 8.7   | 95     | 11.5  | 114    |
| 2200               | 6.1  | 68     | 7.0   | 75     | 7.8   | 84     | 8.8   | 96     | 12.1  | 114    |
| 2400               | 6.3  | 68     | 7.3   | 75     | 8.3   | 85     | 10.5  | 97     | 13.6  | 117    |
| 2600               | 6.5  | 71     | 7.5   | 76     | 8.8   | 86     | 11.3  | 102    | 15.0  | 128    |
| 2800               | 6.6  | 73     | 7.7   | 79     | 9.9   | 95     | 12.9  | 116    | 17.4  | 146    |
| 3000               | 6.7  | 73     | 8.0   | 81     | 10.5  | 97     | 13.8  | 121    | 19.4  | 159    |
| 3200               | 6.8  | 74     | 8.2   | 83     | 10.8  | 101    | 14.6  | 128    | 21.1  | 173    |

The power and current consumption of the actuators (1 W) is not taken into account.

## Electrical cabling - BMS control

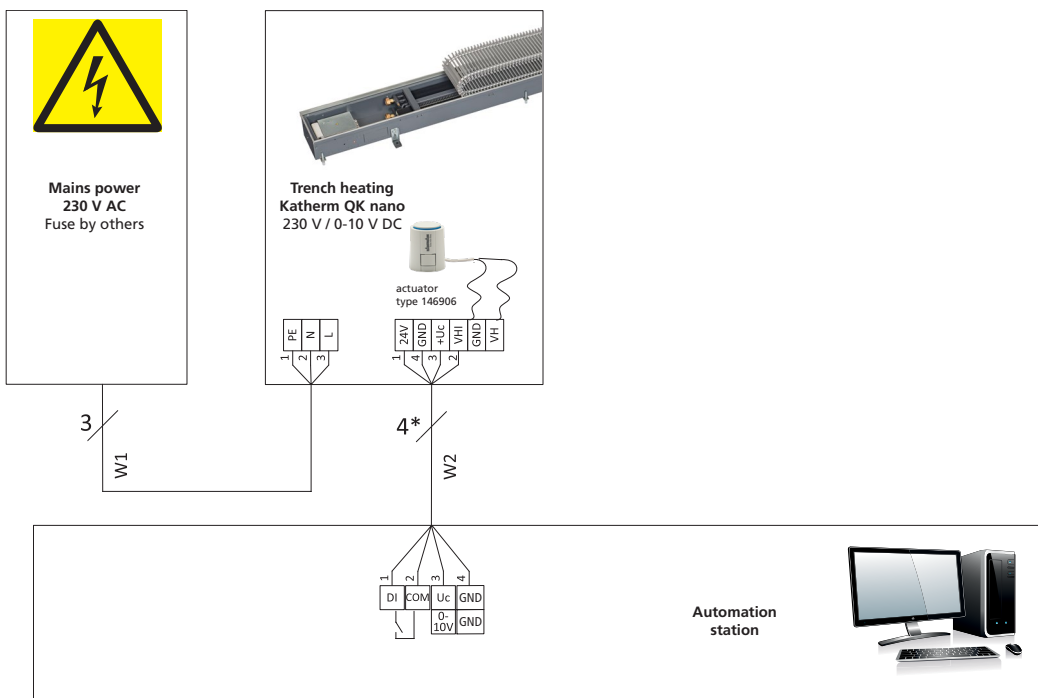

\* Lay shielded cables (e.g. IY(ST)Y, 0.8 mm), separately from high-voltage cables.

W1: Power supply

W2: Control signal for fan and actuator

Subject to technical modifications: Refer to the control accessory documentation in the event of deviation from the circuit diagrams!

## Electrical cabling – control via room thermostat, type 342924

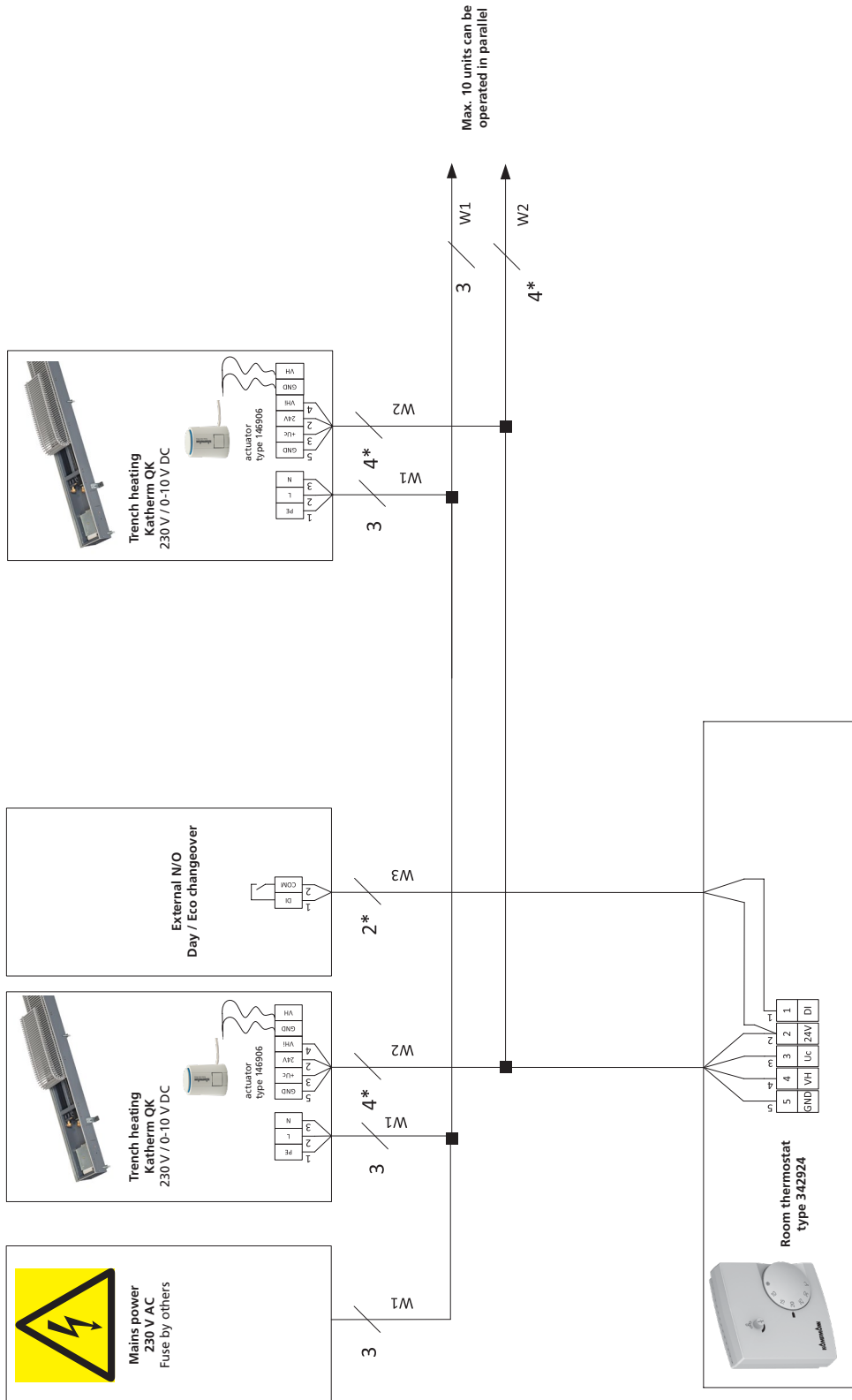

\* Lay shielded cables (e.g. IY(ST)Y, 0.8 mm), separately from high-voltage cables.

W1: Power supply

W2: Control signal for fan and actuator

W3: Operating mode changeover (optional)

Subject to technical modifications: Refer to the control accessory documentation in the event of deviation from the circuit diagrams!

# KaControl model

The all-inclusive solution for room automation and networking

## Product features

- ▶ A high-performance parametrised microprocessor is designed to carry out all necessary functions. Each Katherm QK is therefore equipped with its own "intelligence" and can be operated in groups via Kampmann networks.

## Connection to building automation systems

- ▶ Katherm QK with KaControl can be equipped with plug-in communication interfaces for controlled operation in individual rooms or for linking into higher-order control systems: BACnet, CAN bus, LON, KNX and Modbus. Direct control via an active 0-10 V signal from the on-site building management system is alternatively possible.

## Motor protection

- ▶ Any faults with the motor e.g. overloading are analysed by the electronics within the EC motor. This then switches the fan off.

## KaControl

The parametrisable KaControl offers a wide range of functions:

- ▶ optional: 5 fan speed settings; manually adjustable
- ▶ valve control for 2-pipe applications for thermoelectric valve actuators 24 V DC OPEN/CLOSE
- ▶ integrated timer program for programming day and week switching functions in the KaController unit
- ▶ motor monitoring with fault signal processing

## KaController operating unit



The "face" of the KaControl building automation system: the KaController operating unit.

With a large display and one-touch operation, the KaController is very easy to use. With the basic principle, "as little as possible, as much as required", even untrained users can intuitively get to grips with the control options.

The basic functions for comfortable interior temperatures are set in a user-friendly way using the KaController.

## Product features

- ▶ room control unit, wall-mounted, high-grade design
- ▶ available with or without function buttons on the side
- ▶ plastic housing, colour similar to RAL 9010
- ▶ communication interface to Kampmann T-LAN bus system
- ▶ large display with automatic back light
- ▶ integral room temperature sensor
- ▶ push-turn navigator dial with endless turn/lock function
- ▶ built-in weekly switching program
- ▶ password-protected parameter level

Table with rating values

| Trench length [mm] | QK 190 / QK 215<br>Power consumption P [W]<br>Current consumption I [mA]<br>at fan speed |        |       |        |       |        |       |        |       |        |
|--------------------|--|--------|-------|--------|-------|--------|-------|--------|-------|--------|
|                    | 20%  |        | 40%   |        | 60%   |        | 80%   |        | 100%  |        |
|                    | P [W]  | I [mA] | P [W] | I [mA] | P [W] | I [mA] | P [W] | I [mA] | P [W] | I [mA] |
| 1000               | 3.6  | 54     | 4.1   | 58     | 4.5   | 61     | 5.2   | 68     | 6.3   | 76     |
| 1200               | 3.8  | 56     | 4.5   | 62     | 5.2   | 67     | 6.1   | 73     | 7.7   | 86     |
| 1400               | 4.2  | 58     | 4.8   | 64     | 6.0   | 72     | 7.4   | 84     | 9.2   | 97     |
| 1600               | 4.4  | 60     | 5.2   | 67     | 6.7   | 79     | 8.6   | 95     | 10.9  | 114    |
| 1800               | 4.5  | 65     | 5.4   | 74     | 6.8   | 84     | 8.7   | 95     | 11.5  | 114    |
| 2000               | 4.5  | 65     | 5.4   | 74     | 6.8   | 84     | 8.7   | 95     | 11.5  | 114    |
| 2200               | 6.1  | 68     | 7.0   | 75     | 7.8   | 84     | 8.8   | 96     | 12.1  | 114    |
| 2400               | 6.3  | 68     | 7.3   | 75     | 8.3   | 85     | 10.5  | 97     | 13.6  | 117    |
| 2600               | 6.5  | 71     | 7.5   | 76     | 8.8   | 86     | 11.3  | 102    | 15.0  | 128    |
| 2800               | 6.6  | 73     | 7.7   | 79     | 9.9   | 95     | 12.9  | 116    | 17.4  | 146    |
| 3000               | 6.7  | 73     | 8.0   | 81     | 10.5  | 97     | 13.8  | 121    | 19.4  | 159    |
| 3200               | 6.8  | 74     | 8.2   | 83     | 10.8  | 101    | 14.6  | 128    | 21.1  | 173    |

The power and current consumption of the actuators (1 W) is not taken into account.

## Electrical cabling - 24 V Open / Close valve, external KaController

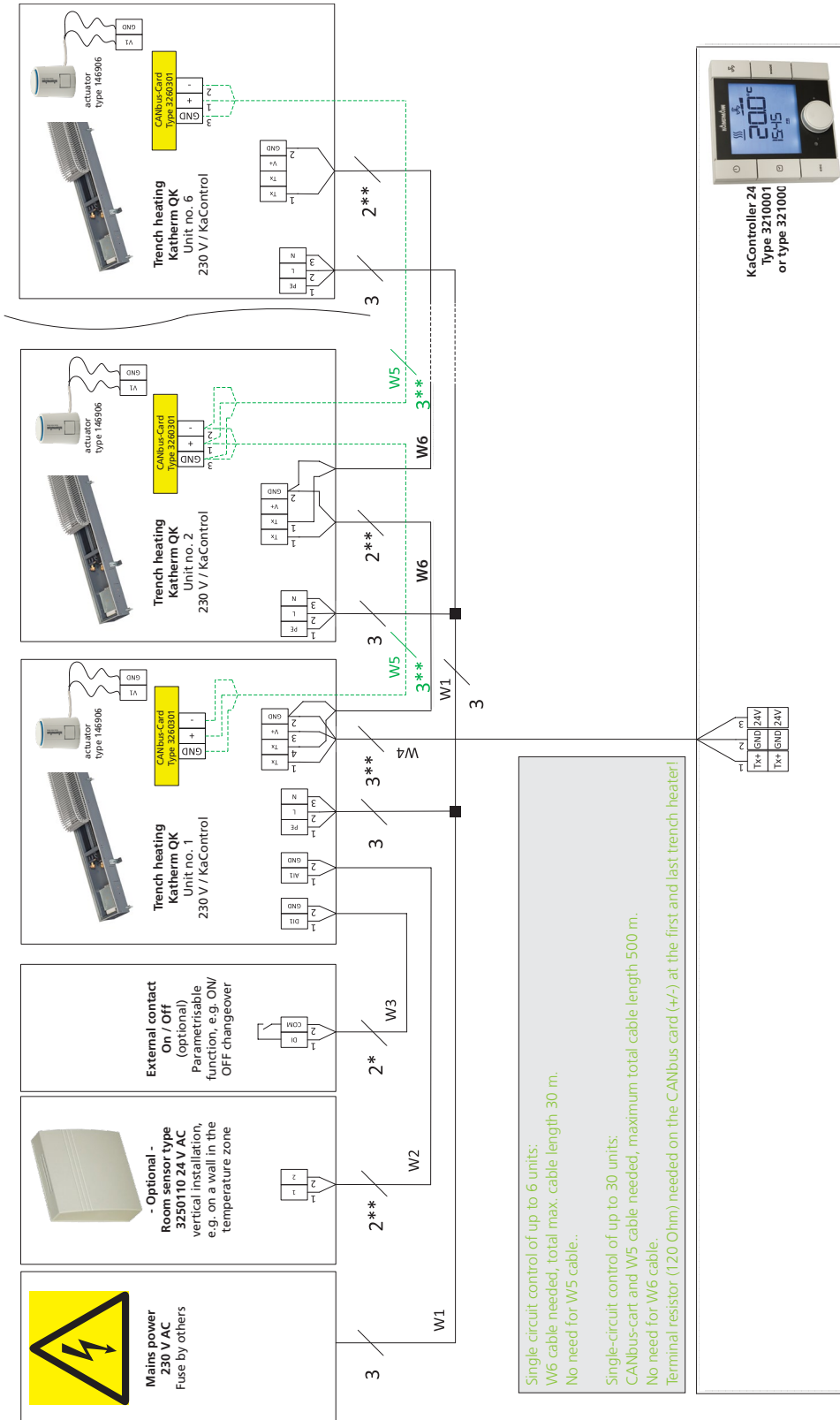

\* Lay shielded cables (e.g. IY(ST)Y 0,8 mm) separately from high-voltage cables.

\*\* Lay shielded, paired cables, e.g. UNITRONIC® BUS LD 2x2x0,22 or equivalent, separately from high-voltage cables.

W1: Power supply

W2: Analogue input AI1 (optional connection), max. cable length 10 m, from 1 mm² 30 m.

W3: Digital input DI1 (optional connection), max. cable length 30 m, from 1 mm² 100 m.

W4/W6: Bus signal (TLan), each max. total cable length 30 m.

W5: Bus signal (CANbus) only needed in a single-circuit control of up to 30 units.

Subject to technical modifications: Refer to the control accessory documentation in the event of deviation from the circuit diagrams!

## KaControl electrical cabling - BMS control

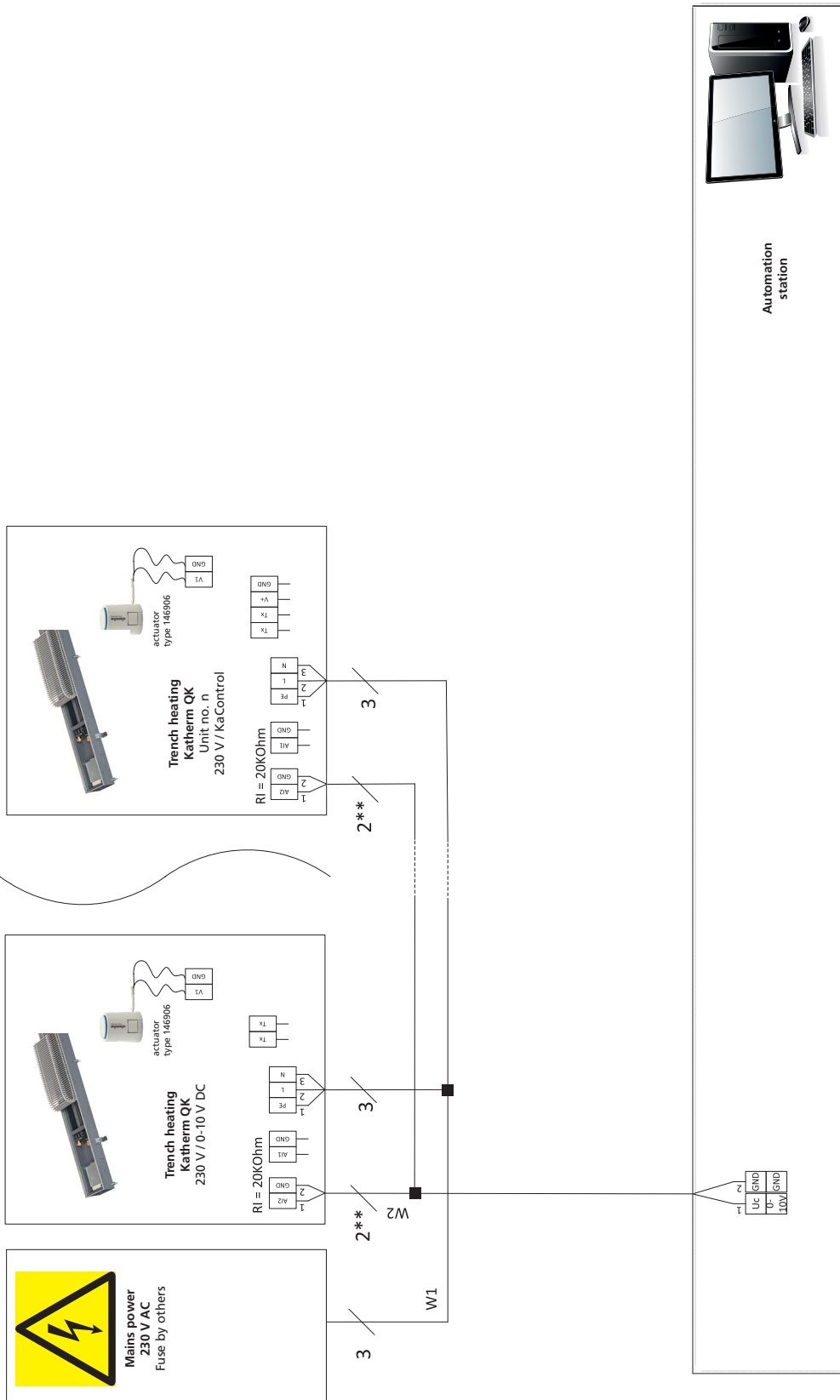

\*\* Lay shielded, paired cables, e.g. CAT5 (AWG23) of at least the same value, separately from high-voltage cables.

W1: Power supply

W2: Control signal for fan and actuator.

Subject to technical modifications: Refer to the control accessory documentation in the event of deviation from the circuit diagrams!

# 05 ▶ Ordering information

## Katherm QK

| Design   | Trench width | Control option          | Grille finish  | Art. no.       |
|--|--------------|-------------------------|----------------|----------------|
|  | [mm]         |                         |                |                |
| Trench length: 1000 mm – 3200 mm<br>Grille bar spacing 12 mm, free area approx. 70% (aluminium, brass)<br>Bar spacing 10.5 mm, free area approx. 65% (stainless steel) |              |                         |                |                |
| QK 190   | 190          | electromechanical 24 V  | Roll-up grille | 14241111111524 |
|  |              |                         | Linear grille  | 14241113111524 |
|  |              | electromechanical 230 V | Roll-up grille | 14241111111500 |
|  |              |                         | Linear grille  | 14241113111500 |
|  |              | KaControl               | Roll-up grille | 142411111115C1 |
|  |              |                         | Linear grille  | 142411131115C1 |
| QK 215   | 215          | electromechanical 24 V  | Roll-up grille | 14243111111524 |
|  |              |                         | Linear grille  | 14243113111524 |
|  |              | electromechanical 230 V | Roll-up grille | 14243111111500 |
|  |              |                         | Linear grille  | 14243113111500 |
|  |              | KaControl               | Roll-up grille | 142431111115C1 |
|  |              |                         | Linear grille  | 142431131115C1 |



| Design  | Trench width | Control option          | Grille finish  | Art. no.       |
|---|--------------|-------------------------|----------------|----------------|
|   | [mm]         |                         |                |                |
| Trench length: 1000 mm – 3200 mm<br>Grille bar spacing 9 mm, free area approx. 65% (aluminium, brass) |              |                         |                |                |
| QK 190  | 190          | electromechanical 24 V  | Roll-up grille | 14242111111524 |
|   |              |                         | Linear grille  | 14242113111524 |
|   |              | electromechanical 230 V | Roll-up grille | 14242111111500 |
|   |              |                         | Linear grille  | 14242113111500 |
|   |              | KaControl               | Roll-up grille | 142421111115C1 |
|   |              |                         | Linear grille  | 142421131115C1 |
| QK 215  | 215          | electromechanical 24 V  | Roll-up grille | 14244111111524 |
|   |              |                         | Linear grille  | 14244113111524 |
|   |              | electromechanical 230 V | Roll-up grille | 14244111111500 |
|   |              |                         | Linear grille  | 14244113111500 |
|   |              | KaControl               | Roll-up grille | 142441111115C1 |
|   |              |                         | Linear grille  | 142441131115C1 |



Trench convectors are supplied as standard with a natural anodised aluminium grille. This can be replaced by one of the following grilles at a surcharge. Please change the two red digits to the left of the red line in the article number to select an alternative grille.

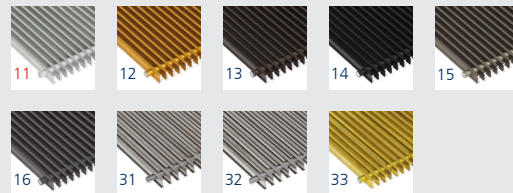

Article key for grille finish (example of art. no.)

- 14241111111500
- 0 → Aluminium, natural anodised (standard)
  - 12 → Aluminium, brass anodised
  - 13 → Aluminium, bronze anodised
  - 14 → Aluminium, black anodised
  - 15 → Aluminium, light bronze
  - 16 → Aluminium, painted DB 703
  - 31 → Stainless steel, natural
  - 32 → Stainless steel, polished
  - 33 → Brass, natural CuZn 44

The available convector lengths are in 200 mm increments (1000 mm to 3200 mm). Please change the two red digits to the right of the red line in the article number to select the required convector length.



Article key for grille finish (example of art. no.)

- 14241111111500
- 0 → Trench length 1000 mm
  - 19 → Trench length 1200 mm
  - 23 → Trench length 1400 mm
  - 27 → Trench length 1600 mm
  - 31 → Trench length 1800 mm
  - 35 → Trench length 2000 mm
  - 39 → Trench length 2200 mm
  - 43 → Trench length 2400 mm
  - 47 → Trench length 2600 mm
  - 51 → Trench length 2800 mm
  - 55 → Trench length 3000 mm
  - 59 → Trench length 3200 mm

## Accessories

| Figure  | Article  | Properties   | Suitable for                        | Art. no.            |
|---|--|--|-------------------------------------|---------------------|
| <b>Valves</b>   |  |  |                                     |                     |
|    | <b>Valve kit</b><br>valve body, 24 V actuator and return fitting | Valve body, straight form, 1/2" connection, pre-settable, return shut-off valve, straight, 1/2" connection, 24 V thermoelectric actuator   | All models                          | <b>194000142110</b> |
|   | <b>Valve body,</b><br>straight, connection 1/2", pre-settable    | As a low-noise, flow-optimised design with stainless steel spindle and double O-ring seal, to fit Katherm QK with actuator art. no. 194000146906.<br>Max operating temperature 120 °C<br>Maximum operating pressure 10 bar | All models                          | <b>194000346909</b> |
|  | <b>Adjustment key</b>  | Pre-settable   | Valve bodies, art. no. 194000346909 | <b>194000346915</b> |
| <b>Return valves</b>  |  |  |                                     |                     |
|  | <b>Return shut-off valve</b><br>straight, connection 1/2"        | Brass, nickel-plated housing with O-ring seal, max. operating temperature 120°C, max. operating pressure 10 bar  | All models                          | <b>194000145952</b> |
| <b>Valve actuators</b>  |  |  |                                     |                     |
|  | <b>Thermoelectric actuator, 24 V</b>                             | Power uptake approx. 1 W,<br>Connecting cable length approx. 1000 mm,<br>Overall height 58 mm, total width 49 mm,<br>with valve adapter ring   | All valve bodies                    | <b>194000146906</b> |

more »

| Figure  | Article  | Properties   | Suitable for                                 | Art. no.            |
|---|--|--|--|---------------------|
| <b>24 V electromechanical control accessories</b>                                   |  |  |  |                     |
|    | <b>Power unit</b><br>for max.<br>1 Katherm QK                  | 230 V AC/24 V: for max. 1 Katherm QK<br>24 V model, for external installation outside the trench convector   | Katherm QK, 24 V<br>electromechanical model  | <b>196901335152</b> |
|   | <b>Power unit</b><br>for max.<br>3 Katherm QK                  | 230 V AC/24 V: for max. 3 Katherm QK<br>24 V model, for external installation outside the trench convector   |  | <b>196901338401</b> |
|  | <b>Power unit</b><br>for max.<br>5 Katherm QK                  | 230 V AC/24 V: for max. 5 Katherm QK<br>24 V model, for external installation outside the trench convector   |  | <b>196901338402</b> |
|  | <b>Clock thermostat type</b><br>30456                          | Clock thermostat 24 V, heating/cooling with 2-pipe system, flush-mounted, continuously variable, with LCD operating menu and integrated timer program, heating/cooling changeover by means of external potential-free contact (low voltage)  | Katherm QK, 24 V<br>electromechanical model  | <b>196000030456</b> |
| <b>230 V electromechanical control accessories</b>                                  |  |  |  |                     |
|  | <b>Room thermostat type</b><br>342924                          | Continuously variable speed controller combined with a thermostat for room temperature dependent two-point control of Katherm QK units. The fan speed is set manually on the speed controller at between 0-100%. The thermostats activate the Katherm QK temperature-dependent in at the pre-set speed.  | Katherm QK, 230 V<br>electromechanical model | <b>194000342924</b> |
| <b>KaControl accessories</b>  |  |  |  |                     |
|  | <b>KaController operating unit</b><br>with one-touch operation | Operating unit, wall-mounted, in high-grade design, plastic housing, colour similar to RAL 9010, large LCD multifunctional display, integrated room temperature sensor, communication interface to Kampmann T-LAN bus system, automatically switching LED backlight, press/turn dial with click stop function, individually adjustable basic display, integrated day, night and week program, password-protected parameter level for C1 control option | Katherm QK, KaControl<br>model               | <b>196003210001</b> |

[more »](#)



| Figure  | Article  | Properties  | Suitable for                  | Art. no.            |
|---|--|---|-------------------------------|---------------------|
|    | <b>KaController operating unit</b><br>with side function keys  | For quick access to fan setting, operating modes, Eco mode, time and timer program, otherwise as art. no. 196003210001                    | Katherm QK, KaControl model   | <b>196003210002</b> |
|   | <b>KaController operating unit</b><br>with one-touch operation | Room control unit for wall mounting, high-quality design, plastic housing, colour similar to RAL 9017, otherwise as art. no. 169003210001 | Katherm QK, KaControl model   | <b>196003210006</b> |
|  | <b>Room temperature sensor</b>                                 | For wall mounting, IP30 surface-mounted, white RAL 9010, alternative to the temperature sensor in the KaController                        | Katherm QK, KaControl model   | <b>196003250110</b> |
|  | <b>Pipe clip-on sensor</b>                                     | For detecting the temperature of the medium, including strap, 3 m cable, to protect the unit from frost                                   | All models                    | <b>196003250115</b> |
|  | <b>Serial CANBus card</b>                                      | To increase the number of units in a single-circuit system to a maximum of 30 units, 1x required per Katherm QK unit                      | Katherm QK<br>KaControl model | <b>196003260301</b> |
|  | <b>Serial Modbus card</b>                                      | For connection to BMS and automation units  | Katherm QK<br>KaControl model | <b>196003260101</b> |
|  | <b>Serial KNX card</b>   | For integration into KNX-/EIB networks  | Katherm QK<br>KaControl model | <b>196003260701</b> |
| <b>Other accessories</b>  |  |   |                               |                     |
|  | <b>Installation cover</b>                                      | Made of wood to provide protection during installation, factory-fitted<br>Grilles are supplied separately                                 | Katherm QK 190                | <b>194000100919</b> |
|   |  |   | Katherm QK 215                | <b>194000100922</b> |





[kampmanngroup.com/katherm-qk](http://kampmanngroup.com/katherm-qk)  
[kampmanngroup.com/katherm-qk-nano](http://kampmanngroup.com/katherm-qk-nano)  
[Kampmann.co.uk/katherm-qk](http://Kampmann.co.uk/katherm-qk)  
[Kampmann.co.uk/katherm-qk-nano](http://Kampmann.co.uk/katherm-qk-nano)

**Kampmann GmbH & Co. KG**  
Friedrich-Ebert-Str. 128 - 130  
49811 Lingen (Ems)  
Germany

**T** +49 591 7108-660  
**F** +49 591 7108-173  
**E** [export@kampmann.de](mailto:export@kampmann.de)  
**W** [Kampmanngroup.com](http://Kampmanngroup.com)

**Kampmann UK Ltd.**  
Dial House, Govett Avenue  
Shepperton, Middlesex, TW17 8AG  
Great Britain

**T** +44 (0)1932 228592  
**F** +44 (0)1932 228949  
**E** [info@kampmann.co.uk](mailto:info@kampmann.co.uk)  
**W** [Kampmann.co.uk](http://Kampmann.co.uk)

