

# Ultra Allround

► Assembly, installation and operating instructions

Keep these instructions in a safe place for future use!



## Table of contents

<b>1 General</b> .....	<b>5</b>
1.1 About these instructions .....	5
1.2 Explanation of Symbols.....	5
<b>2 Safety</b> .....	<b>6</b>
2.1 Correct use.....	6
2.2 Limits of operation and use.....	6
2.3 Risk from electrocution!.....	8
2.4 Personnel requirements - Qualifications .....	9
2.5 Personal Protective Equipment .....	9
<b>3 Transport, storage and packaging</b> .....	<b>10</b>
3.1 General transport instructions .....	10
3.2 Scope of delivery.....	10
3.3 Storage .....	11
3.4 Packaging .....	11
<b>4 Technical data</b> .....	<b>13</b>
<b>5 Construction and function</b> .....	<b>14</b>
5.1 Overview.....	14
5.2 Brief description.....	14
5.3 Wear parts list.....	15
<b>6 Installation and wiring</b> .....	<b>16</b>
6.1 Requirements governing the installation site.....	16
6.2 Installation height and throws .....	16
6.3 Minimum clearances.....	16
6.4 Installation .....	17
6.4.1 Ultra suspension points .....	17
6.4.2 Installation of the Ultra Allround .....	19
6.4.3 Fitting the filter attachment (optional accessory) .....	21
6.4.4 Fitting the primary air spigot (optional accessory).....	21
6.5 Installation .....	22
6.5.1 Connection to the pipe network .....	24
6.6 Condensation connection .....	25
6.6.1 Condensate drainage using a condensate pump .....	25
6.6.2 Commissioning and functional checks.....	25
<b>7 Electrical connection</b> .....	<b>26</b>

7.1	Maximum electrical rating values .....	26
7.2	Electromechanical control .....	26
7.2.1	Connection (*00) .....	26
7.3	KaControl (*C1) .....	36
7.3.1	KaController installation .....	36
7.3.2	Connection (*C1) .....	37
<b>8</b>	<b>Pre-commissioning checks .....</b>	<b>45</b>
<b>9</b>	<b>Operation .....</b>	<b>46</b>
9.1	Operation of electromechanical control .....	46
9.2	Operation of the KaController .....	49
9.2.1	Function keys, display elements .....	50
<b>10</b>	<b>Maintenance .....</b>	<b>52</b>
10.1	Securing against reconnection .....	52
10.2	Maintenance Schedule: .....	52
10.3	Maintenance work .....	52
10.3.1	Visual checks .....	53
10.3.2	Clean the inside of the unit .....	53
10.3.3	Dismantling the housing cover .....	53
10.3.4	Cleaning the condensate tray .....	54
10.3.5	Cleaning the condensate pump .....	55
10.3.6	Replacing the filter. ....	57
<b>11</b>	<b>Faults .....</b>	<b>58</b>
11.1	Fault table .....	58
11.2	KaControl faults .....	58
11.3	Start-up after rectification of fault .....	59
<b>12</b>	<b>List of KaControl parameters .....</b>	<b>60</b>
12.1	KaController parameter list .....	60
<b>13</b>	<b>Certificates .....</b>	<b>61</b>



## 1 General

### 1.1 About these instructions

These instructions ensure the safe and efficient handling of this equipment. These instructions form an integral part of the equipment and have to be kept in the direct vicinity of the equipment and available to personnel at all times.

All personnel must have carefully read through these instructions prior to commencing all work on the equipment. A fundamental prerequisite for safe working is compliance with all the stated safety instructions and other instructions contained in this manual.

In addition all local occupational health and safety at work regulations apply, as do general safety provisions governing the use of the equipment.

Illustrations in this guide are intended to provide a basic understanding and may differ from the actual model.

Ongoing tests and further developments may result in small variations between the unit supplied and the instructions.

### 1.2 Explanation of Symbols



#### **DANGER!**

This combination of symbol and signal word indicates an immediately dangerous situation caused by electrical power, which will cause death or serious injury if not avoided.



#### **WARNING!**

This combination of symbol and signal word indicates a possible hazardous situation.



#### **IMPORTANT NOTE!**

It represents a potentially hazardous situation, which could lead to damage to property or for a measure to optimise workflows.



#### **IMPORTANT NOTE!**

This symbol highlights useful hints, recommendations and information for efficient and trouble-free operation.

# Ultra Allround

Assembly, installation and operating instructions

## 2 Safety

This section provides an overview of all important safety aspects to ensure optimum protection of personnel as well as safe and trouble-free operation. In addition to the safety instructions in these operating instructions, the valid safety, accident prevention and environmental protection regulations must be observed for the area of use of the unit. It is the duty of the operator to ensure that instructions relating to maintenance (e.g. relating to hygiene) are complied with.

### 2.1 Correct use

The units are only intended to be used for heating and cooling air in frost-free and dry rooms. Within the room, the unit needs to be connected to the building's heating/cooling/ventilation system and to the building's waste water and power network. The operating limits and limits of use described in Chapter 2.2 [▶ 6] must be observed.



#### **IMPORTANT NOTE!**

Only use the unique after completion of the complete building and system. Site heating is not deemed to be correct and proper use.

Intended use of the unit also includes adherence to these instructions.

#### **Information in accordance with EN60335-1**

- ▶ This unit can be used by children aged 8 years or more and also by people with reduced physical, sensory or mental capabilities or a lack of experience and knowledge, if they are supervised or have been instructed in the safe use of the unit and the resulting dangers. Do not allow children to play with the unit. Do not allow children to clean and maintain the unit without supervision.
- ▶ The unit is not intended for operation above 2,000 m.a. s.l.
- ▶ This unit is not intended for permanent connection to the drinking water network.
- ▶ This unit is designed to be accessible to the general public.

Any use beyond or other than the stated intended use is considered as misuse.

Any modification to the unit or use of non-original spare parts will cause the expiry of the warranty and will invalidate the manufacturer's liability.

## 2.2 Limits of operation and use

Limits of operation		
Min./max. water temperature	°C	5-90
Min./max. air intake temperature	°C	-20 - (+40)
Min./max. air humidity	%	15-75
Min. operating pressure	bar/kPa	16
Max. operating pressure	bar/kPa	siehe Typenschild
Min./max. glycol percentage	%	25-50

Tab. 1: Limits of operation

<b>Operating voltage</b>	<b>230 V/ 50/60 Hz</b>
Power/current consumption	On the typeplate

Tab. 2: Operating voltage

We would refer to VDI-2035 Sheets 1 & 2, DIN EN 14336 and DIN EN 14868 with regard to the properties of the medium used to protect the equipment. The following values provide further guidance.

The water used should be free of contamination, such as suspended substances and reactive substances.

Water quality		
pH value (at 20 °C)		8-9
Conductivity (at 20 °C)	µS/cm	< 700
Oxygen content (O <sub>2</sub> )	mg/l	< 0.1
Hardness	°dH	4-8.5
Sulphur ions		not measurable
Sodium ions (Na <sup>+</sup> )	mg/l	< 100
Iron ions (Fe <sup>2+</sup> )	mg/l	< 0.1
Manganese ions (Mn <sup>2+</sup> )	mg/l	<0.05
Ammonia ions (NH <sup>4+</sup> )	mg/l	< 0.1
Chlorine ions (Cl)	mg/l	< 100
CO <sub>2</sub>		< 50
Sulfate ions (SO <sub>4</sub> <sup>2-</sup> )	mg/l	< 50
Nitrite ions (NO <sub>2</sub> <sup>-</sup> )	mg/l	< 50
Nitrate ions (NO <sub>3</sub> <sup>-</sup> )	mg/l	< 50

Tab. 3: Water quality

# Ultra Allround

Assembly, installation and operating instructions



## IMPORTANT NOTE!

### Danger of frost in cooling mode!

There is a risk of the heat exchanger freezing when used in unheated rooms.

- ▶ Make sure that the unit is equipped with a frost protection sensor and/or thermostat in this case.



## IMPORTANT NOTE!

### Warning of misuse!

In the event of misuse, as itemised below, there is a danger of limited or failing operation of the unit. Ensure that the airflow can circulate freely.

- ▶ Never operate the unit in humid areas, such as swimming pools, wet areas etc.
- ▶ Never operate the unit in rooms with an explosive atmosphere.
- ▶ Never operate the unit in aggressive or corrosive atmospheres (e.g. sea air).
- ▶ Never operate the unit above electrical equipment (such as switch cabinets, computers or other electrical units, or contacts that are not drip-proof).
- ▶ Never use the unit as a construction site heater.
- ▶ Never operate the unit in areas with a high dust content.



## IMPORTANT NOTE!

### Energy losses due to misuse!

Operating the unit with open windows (or other room openings) can result in significant energy losses.

- ▶ Heating and cooling modes (particularly when operating different units) need to be coordinated with each other.

## 2.3 Risk from electrocution!



## DANGER!

### Risk of fatal injury from electrocution!

Contact with live parts will lead to fatal injury from electrocution. Damage to the insulation or individual components can lead to a fatal injury.

- ▶ Only permit qualified electricians to work on the electrical system.
- ▶ Immediately disconnect the system from the power supply and repair it in the event of damage to the insulation.
- ▶ Keep live parts away from moisture. This can cause a short circuit.
- ▶ Properly earth the unit.

## 2.4 Personnel requirements - Qualifications

### Expertise

The installation of this product requires specialist expertise in heating, cooling, ventilation, installation and electrical engineering. As this knowledge is normally acquired through professional training in one of the above fields, it is not dealt with further here.

Damage caused by improper installation is the responsibility of the operator or installer. Installers of these units should have adequate knowledge of the following based on their qualifications

- ▶ Safety and accident prevention regulations
- ▶ Guidelines and recognised technical regulations, i.e. VDE regulations (Association of German Electricians, DIN and EN standards).
- ▶ VDI 6022; maintenance personnel must be trained to Category B (possibly Category C) to comply with hygiene requirements (as required).

The installation, operation and maintenance of this unit must comply with the applicable laws, standards, provisions and regulations in the respective country and the current state of the art.

## 2.5 Personal Protective Equipment

Personal protective equipment is used to protect people from impaired safety and health when working with the unit. The applicable accident prevention regulations at the place of use apply in all cases.

Personnel have to wear personal protective equipment during maintenance and troubleshooting on and with the unit.

# Ultra Allround

Assembly, installation and operating instructions

## 3 Transport, storage and packaging

### 3.1 General transport instructions

Check on delivery for completeness and transport damage.

Proceed as follows in the event of visible damage:

- ▶ Do not accept delivery or only accept with reservations.
- ▶ Record any transport damage on the transportation documents or on the transport company's delivery note.
- ▶ Submit a complaint to the freight forwarder.



#### IMPORTANT NOTE!

Warranty claims can only be made within the applicable period for complaints. (More information is available in the T&Cs on the Kampmann website)



#### IMPORTANT NOTE!

2 people are needed to transport the unit. Wear personal protective clothing when transporting the unit. Only lift the unit on both sides and not by the pipes / valves.



#### IMPORTANT NOTE!

##### Material damage caused by incorrect transport!

Units being transported can drop or topple over if transported wrongly. This can cause serious material damage.

- ▶ Proceed carefully when unloading the equipment on delivery and when transporting it on site, and note the symbols and instructions on the packaging.
- ▶ Only lift the unit with the outer packaging fitted to avoid damage. Only use the recessed grips provided in the box.
- ▶ Only remove the outer packaging once the unit has been assembled. The packaging is used to protect against dirt and damage on site.

### 3.2 Scope of delivery



#### IMPORTANT NOTE!

##### Check the scope of delivery!

- ▶ Check the delivery for damage.
- ▶ Check that the articles and type numbers are correct.
- ▶ Is the delivery and number of items delivered correct?

## 3.3 Storage

Store packaging under the following conditions:

- ▶ Do not store outdoors.
- ▶ Store in a dry and dust-free place.
- ▶ Store in a frost-free place.
- ▶ Do not expose to aggressive media.
- ▶ Protect from direct sunlight.
- ▶ Avoid mechanical vibrations and shocks.



### **IMPORTANT NOTE!**

Under certain circumstances, packages can carry storage instructions that exceed the requirements listed here. Comply with these instructions accordingly.

# Ultra Allround

Assembly, installation and operating instructions

## 3.4 Packaging

Handling packaging materials



### IMPORTANT NOTE!

Dispose of packaging materials in line with the applicable statutory requirements and local regulations.



### IMPORTANT NOTE!

The packaging is also used to protect the product from site dust and dirt. Only remove packaging shortly before assembling the unit.

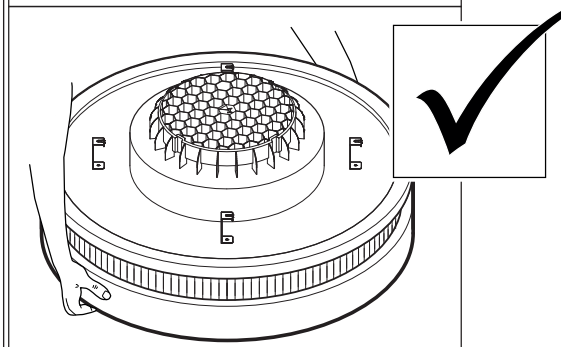
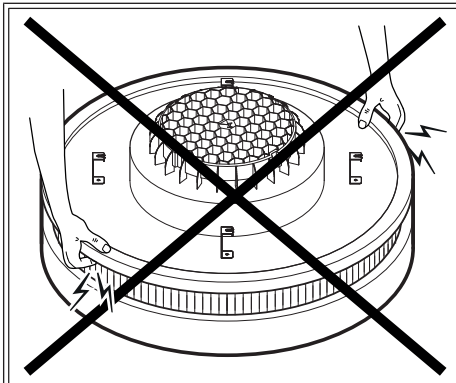

The packaging serves as a transport aid as well as dust and assembly protection. Only remove the packaging properly shortly before commissioning.

If the Ultra Allround is carried/mounted without the outer packaging, lift the device only by the underside!



Fig. 1: Ultra mounted with outer packaging



## 4 Technical data

Size	1	2
Water capacity [l]	3	3.5
Weight [kg]	61	80
Sound power level [db(A)]	<70	<73
Diameter [mm]	1300	1300
Height [mm]	516	516

Tab. 4: Technical specifications Ultra Allround

# Ultra Allround

Assembly, installation and operating instructions

## 5 Construction and function

### 5.1 Overview

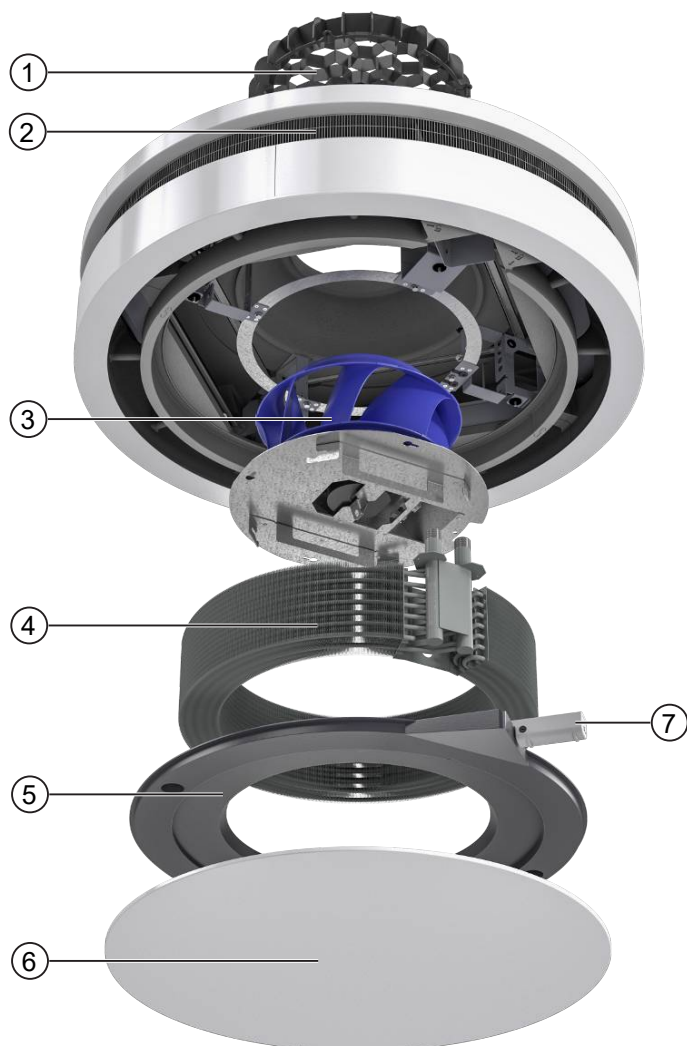

Fig. 2: Ultra Allround at a glance

1	Pre-guide grid	2	Air outlet 360°
3	Fan unit	4	Heat exchanger
5	Condensate tray	6	Inspection hatch with twist lock and drop safety device (wire ropes)
7	Condensate pump		

### 5.2 Brief description

Ultra Allround ceiling-mounted unit heaters, heating and/or cooling models, are used for the decentralised heating and ventilation of halls, exhibition halls and sales rooms. Air is drawn in through the radial fan and is blown through the circular heat exchanger into the room. The heated or cooled air is guided into the room on-demand in a circular horizontal or vertical air stream.

## 5.3 Wear parts list

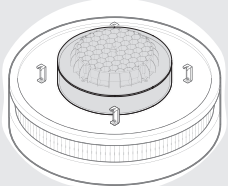
Illustration	article	Features	Suitable for	Item no.
	Filter mat		Size 1 and 2	2035807

# Ultra Allround

Assembly, installation and operating instructions

## 6 Installation and wiring

### 6.1 Requirements governing the installation site

Only install and assemble the unit if the following conditions are met:

- ▶ Make sure that the unit is securely suspended/standing.
- ▶ Ensure that the airflow can circulate freely.
- ▶ Provide adequate space for appropriately sized flow and return water connections on site (Connection to the pipe network [▶ 24]).
- ▶ There is a power supply on site (Maximum electrical rating values [▶ 26]).

### 6.2 Installation height and throws

When suspending the units, pay attention to the maximum installation heights and throws! Make sure that the units are suspended vibration-free (using rubber vibration elements if necessary).

With an installation height of < 3.5 m, make sure that the air is discharged horizontally in heating mode to avoid draughts in the occupied zone.

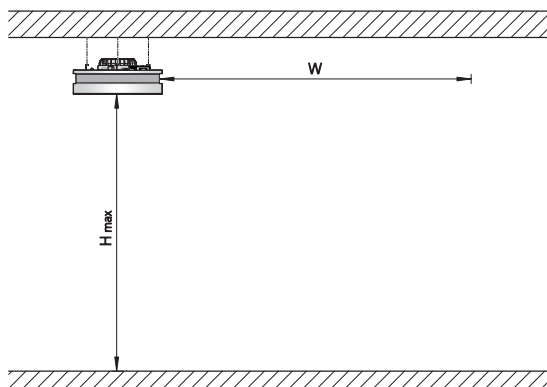

Fig. 3: Maximum installation heights and throws

Control voltage [V]	Max. mounting height [m] H max*		Throw [m] W*	
	Size 1	Size 2	Size 1	Size 2
2	2.5	2.3	<1.5	<1.5
4	3.9	4.1	1.8	1.9
6	5.4	5.7	2.7	2.9
8	7.0	7.3	3.6	3.9
10	8.6	9.0	4.6	4.9
	*35/30/20		*7/12/26	

## 6.3 Minimum clearances

Maintain the minimum clearance of 100 mm between the intake area of the unit and the ceiling! There is then no need to retrofit a filter! Allow a minimum of 200 mm to retrofit a filter!

If you do not leave this minimum distance, the unit heater output will be reduced and the noise level will increase.

Be sure to observe the minimum clearances when using accessories or for maintenance purposes!

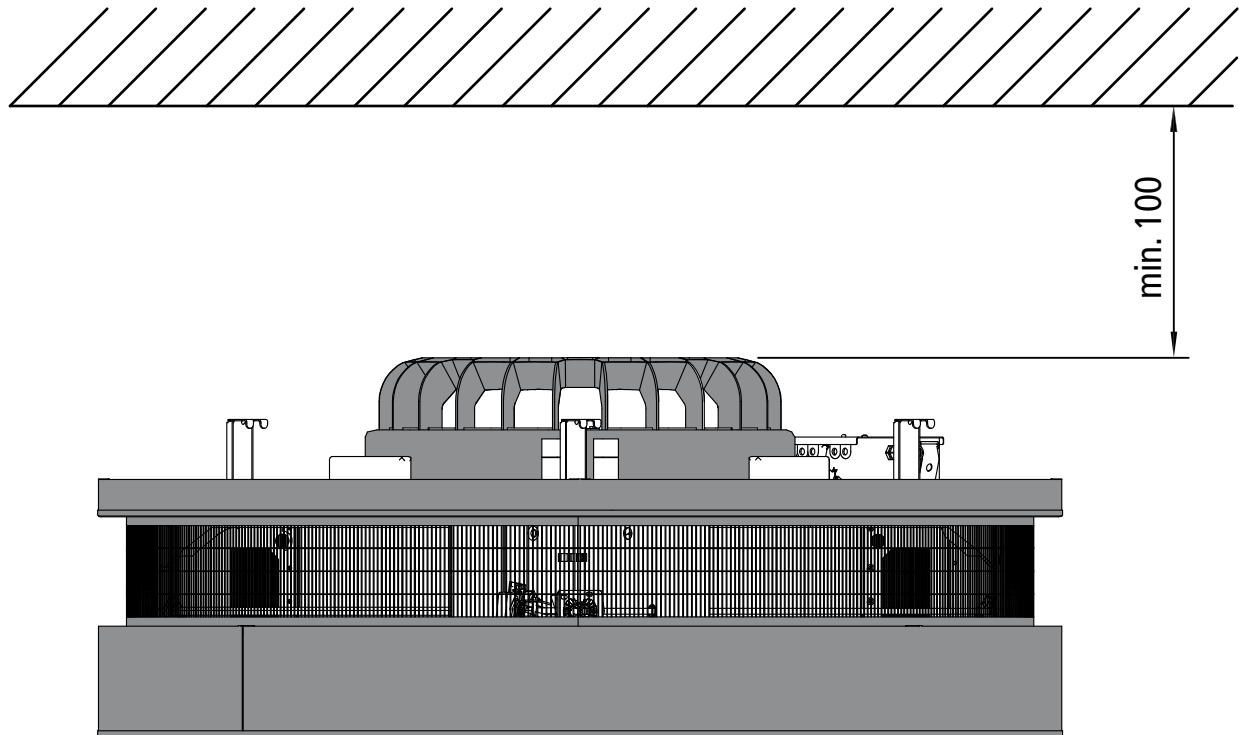

Fig. 4: Minimum clearances with the Ultra Allround

## 6.4 Installation

Appropriate technical lifting equipment or 4 people are required for installation.



### CAUTION!

#### Risk of injury from sharp metal housing!

The inner metal of the casing can have sharp edges.

- ▶ Wear suitable protective gloves.



### IMPORTANT NOTE!

#### Horizontal installation of units!

When installing the units, ensure that they are completely horizontal to ensure proper operation.



### IMPORTANT NOTE!

#### Avoid draughts!

Consider the occupied zone when installing/suspending the units. Do not expose people to the direct air flow. Position the unit accordingly and adjust the air outlet if required.

# Ultra Allround

Assembly, installation and operating instructions

## 6.4.1 Ultra suspension points

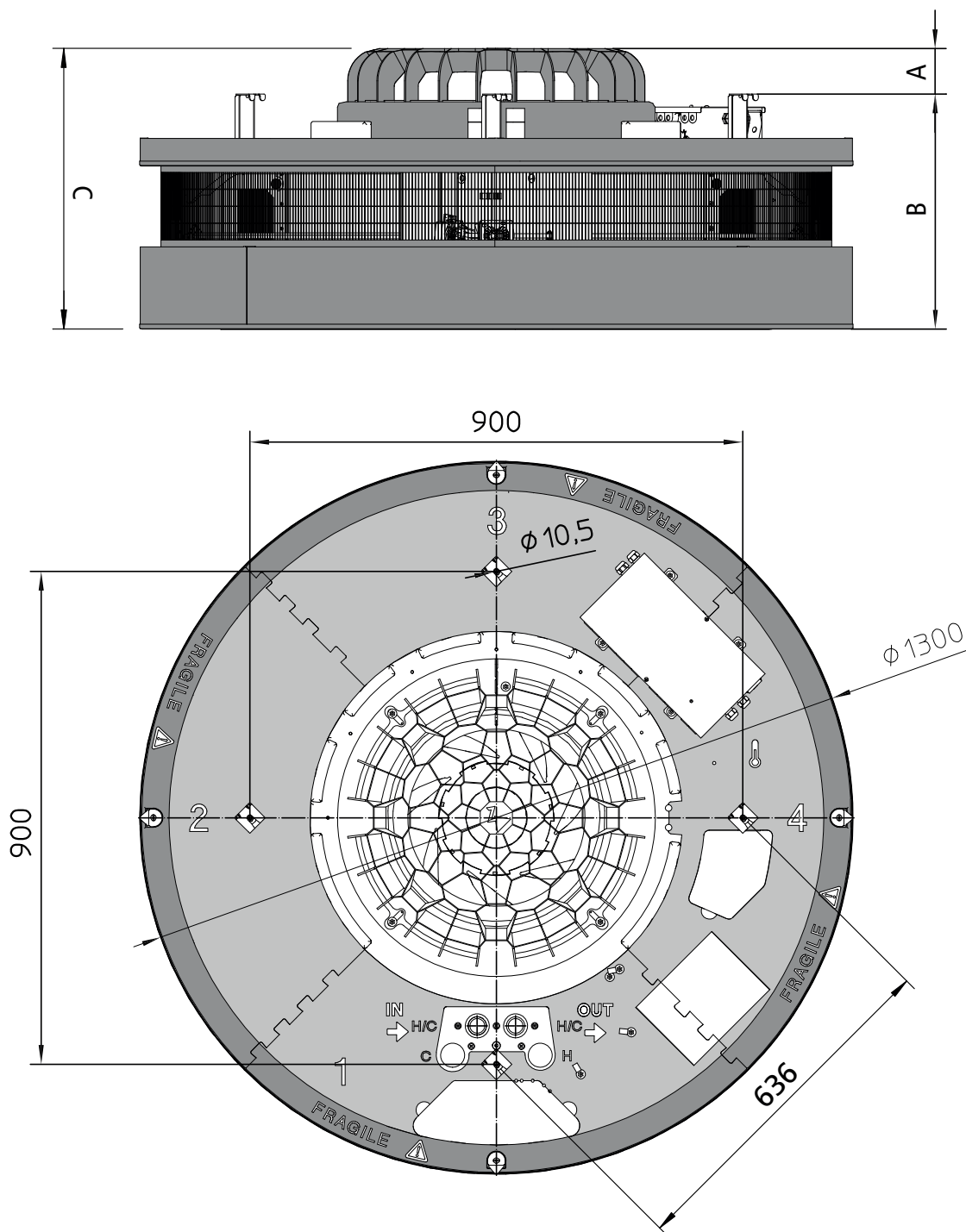

Fig. 5: Ultra Allround suspension points

	Size 1	Size 2
A [mm]	136	86
B [mm]	380	430
C [mm]	516	516

## 6.4.2 Installation of the Ultra Allround

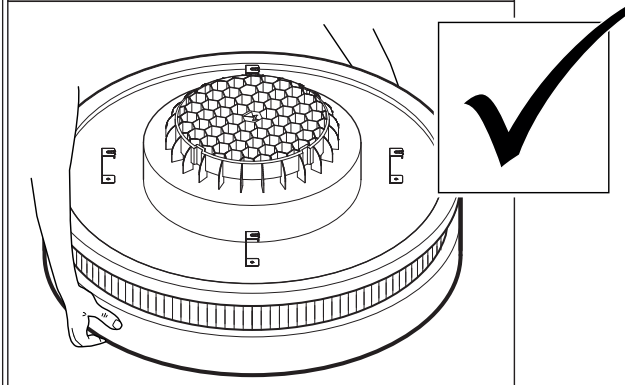
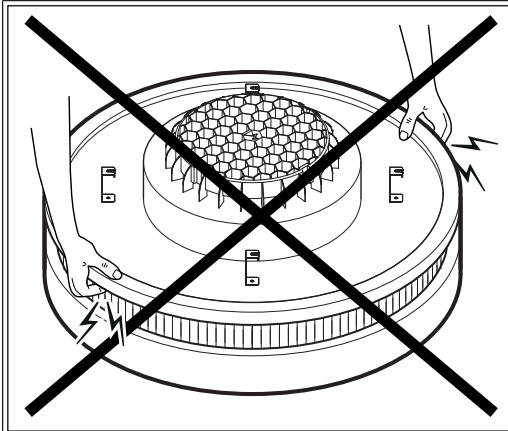

Fig. 6: Ultra mounted with outer packaging

The packaging serves as a transport aid as well as dust and assembly protection. Only remove the packaging properly shortly before commissioning.

If the Ultra Allround is carried/mounted without the outer packaging, lift the device only by the underside!

# Ultra Allround

Assembly, installation and operating instructions

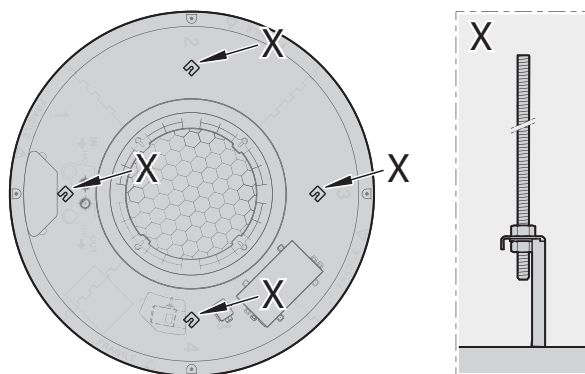
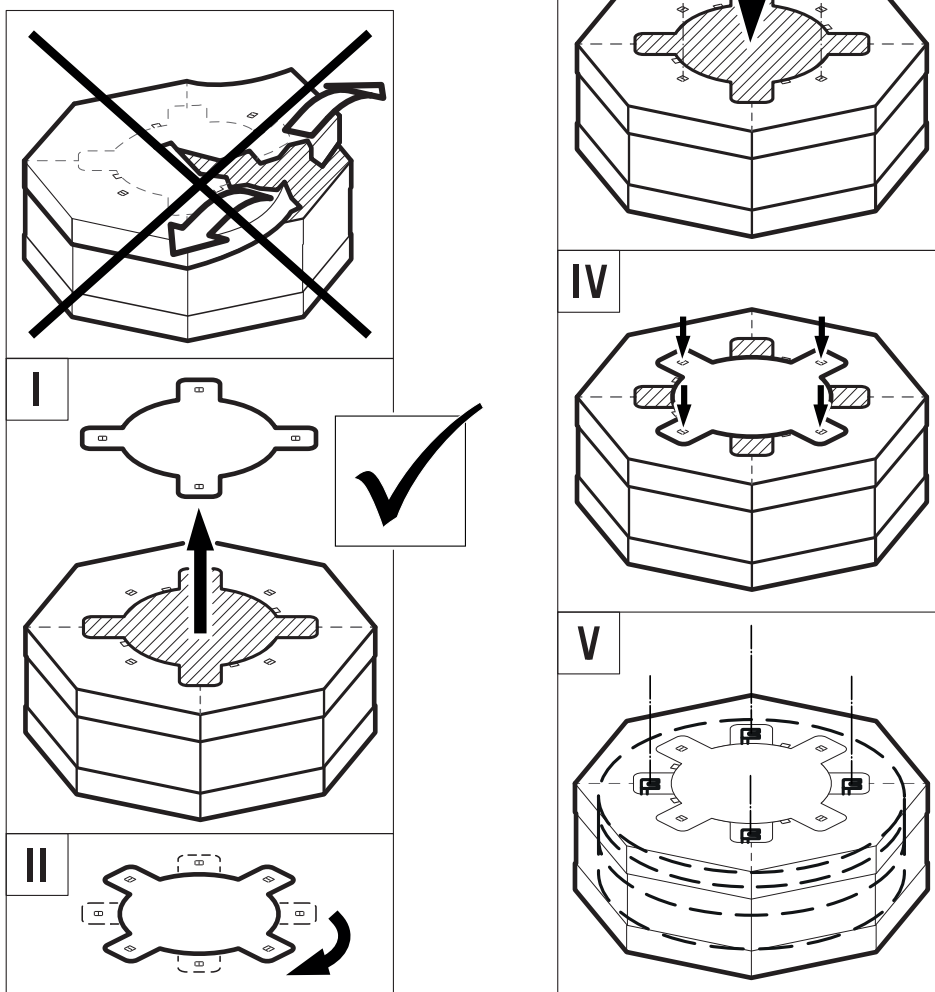

Fig. 7: Diagram: Suspension of the Ultra Allround (Example with threaded rods)

- ▶ Use threaded rods (by others) to suspend the unit by the 4 mounting brackets.
- ▶ Lock the threaded rods in place with nuts and washers.



## 6.4.3 Fitting the filter attachment (optional accessory)

### Note

We recommend fitting the optional accessories **before** actually installing the unit on the ceiling.

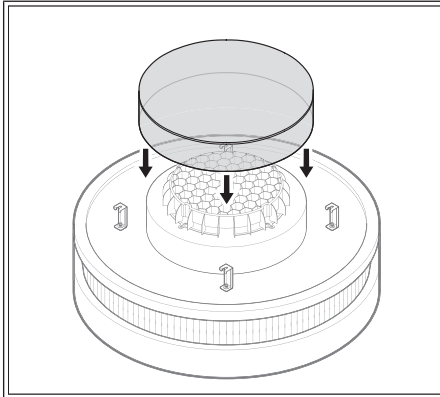

- ▶ Place the filter hood completely over the grille.

# Ultra Allround

Assembly, installation and operating instructions

## 6.4.4 Fitting the primary air spigot (optional accessory)

### Note

We recommend fitting the optional accessories **before** actually installing the unit on the ceiling.

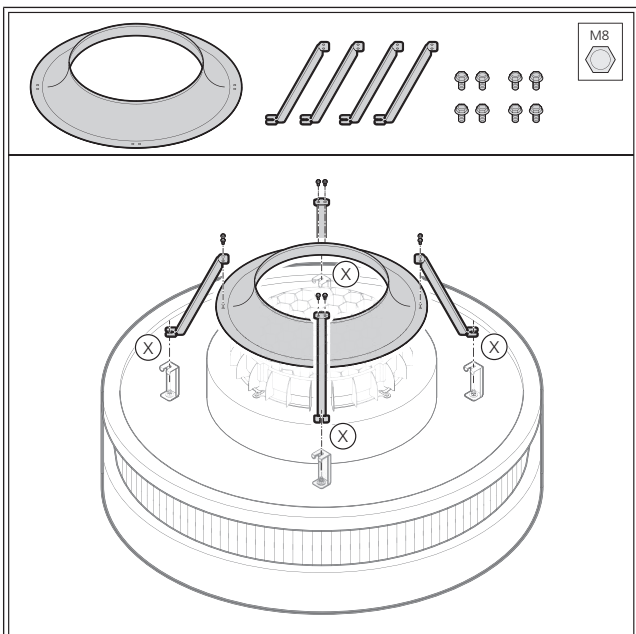
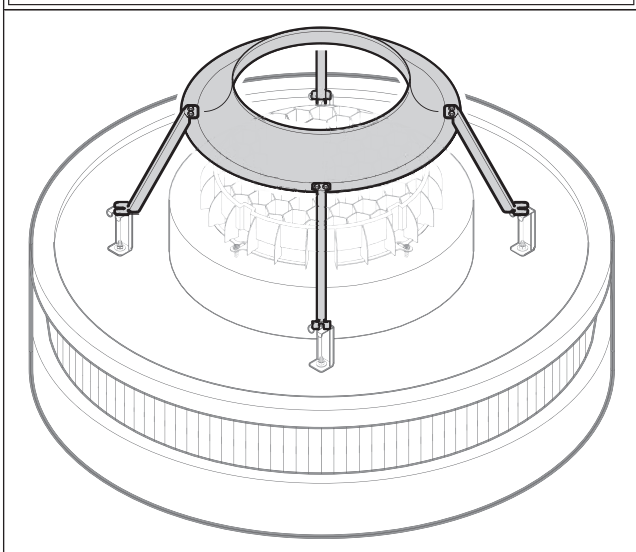
	<ul style="list-style-type: none"><li>▶ Use the screws (M8) provided to attach the spigot to the nozzle.</li></ul>
	<ul style="list-style-type: none"><li>▶ Fit the primary air spigot to the unit.</li></ul>

## 6.5 Installation

### Hydraulic connection

Note the following points when connecting the hydraulic side:

- ▶ Install and test safety components (expansion vessels, pressure relief valves and overflow valves).
- ▶ Route condensation lines with a sufficient cross-section without bends and narrow sections with a gradient to the in situ waste water pipe.
- ▶ Allow adequate space for the air flow (air inlet and outlet).

Observe the following additional points for cooling operation:

- ▶ Install continuous, vapor diffusion-tight insulation on all water-bearing components (piping, valves, connections), in each case up to the unit.
- ▶ Select suitable pipe hangers (cold clamps) for cooling operation.
- ▶ Sufficiently dimension the diameter of the condensate pipe.
- ▶ Protect siphons (if any) in the condensate pipe from drying out.

# Ultra Allround

Assembly, installation and operating instructions

## 6.5.1 Connection to the pipe network



### IMPORTANT NOTE!

#### Using flexible pipes

The use of flexible pipes (such as braided pipe connections, spiral or corrugated pipes) is recommended when installing the unit under a solid ceiling. When used in conjunction with appropriate shut-off valves, this makes it possible to dismantle the unit relatively easily (for example when disassembling the fan). With certain unit designs, the fans can only be replaced once the unit has been completely disassembled.

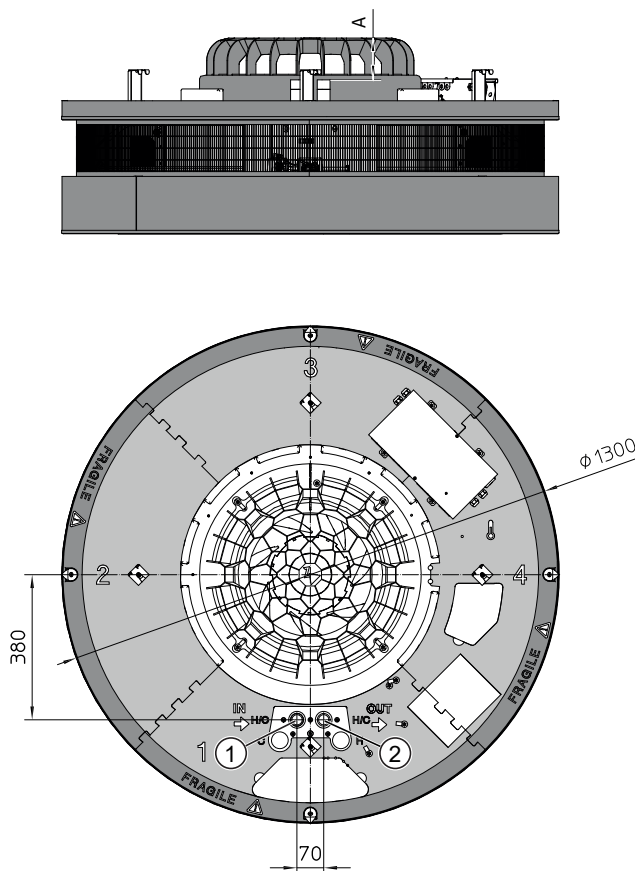

Fig. 8: Connection dimensions Ultra Allround

	Size 1	Size 2
A [mm]	159	109
1	Flow 1"	Return 1"
2	Flow 1"	Return 1"

Proceed as follows when connecting hydraulically:

- ▶ Shut off the supply line from the medium.
- ▶ Create connection piping.
- ▶ Remove the protective covers from the supply and return pipes.
- ▶ Seal and screw in the valve connections.

**Caution! Secure the connecting piece against shearing and twisting using a suitable tool (e.g. pipe wrench). The connections must be mounted mechanically tension-free!**

## 6.6 Condensation connection

### 6.6.1 Condensate drainage using a condensate pump

The water is drawn off by the condensate pump and discharged along a hose connected on the pressure side. Depending on conditions on site, the water can be discharged into drainage lines, possibly with a trap connection. The hose length from the unit is 700 mm, with a diameter of 6 mm (1/4").

In the event of a fault with the condensate drain, the water level will continue to rise until the float switch triggers an alarm contact. The contact can be analysed by external signalling devices.

If the alarm contact is triggered, cooling mode is automatically switched off on the water side if a 24 V valve is factory fitted. Valves provided by the customer need to be closed after an alarm contact.

### Condensate drain

- ▶ Drainage of condensate from the condensate pump must be along a natural gradient with an adequate cross-section (minimum 1/2"). Increase the cross-section with longer condensate lines.
- ▶ Check whether the condensate line needs to be insulated to prevent the build-up of condensate along the line.
- ▶ Never use a rigid transition to the on-site condensate drain. We would recommend a free overflow into a trap.

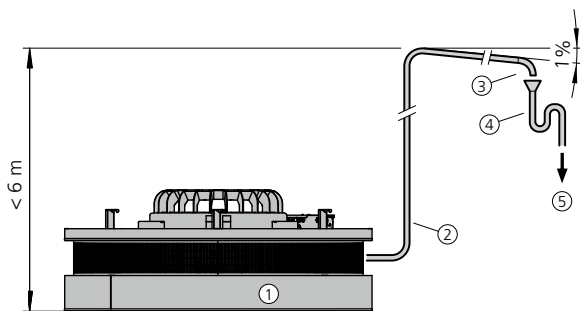

Fig. 9: Condensate drainage diagram

1	Ultra Allround	2	Condensate line
3	Free outlet (DIN EN 1717)	4	Odour trap
5	Waste water network		

### 6.6.2 Commissioning and functional checks

- ▶ Switch on the mains power.
- ▶ Pour water into the condensate tray. The pump should switch on automatically and switch itself off again.
- ▶ Test the alarm switch: Add water until the alarm switch is triggered (acoustic or visual warning message, fan switches off or similar).

# Ultra Allround

Assembly, installation and operating instructions

## 7 Electrical connection

### 7.1 Maximum electrical rating values

#### Electromechanical version

Item no.	Rated voltage [V]	Power frequency [Hz]	Active power [kW]	Rated current [A]	Leakage current [mA]	Maximum backup fuse [A]	IP protection class	Protection class
354xxxx7xx5800	230	50	268	1.2	<3.5	C16	IP20	I
354xxxx7xx58C1	230	50	268	1.2	<3.5	C16	IP20	I

Tab. 5: Electrical specifications Ultra

### 7.2 Electromechanical control

#### 7.2.1 Connection (\*00)

##### Circuit description

- ▶ All units need a 230 V AC power supply
- ▶ A lockable repair switch is always fitted to the electrical housing, and connected.
- ▶ Factory-fitted actuators are wired to the terminals. The appropriate terminals are available for valve actuators.
- ▶ Only 24 V DC valve actuators (Open/Closed or continuous) can be connected.
- ▶ The speed of the EC fans is controlled by a 0-10 V DC signal from the KaControl. The "intelligent" motor electronics detects any possible motor malfunction and automatically switches off the fan.
- ▶ The cooling valve (Y1) is actively closed in the event of a condensate alarm.
- ▶ A motor malfunction signal is available to the potential-free contact f.e1/f.e2 (30 V DC / 2 A).
- ▶ A condensate alarm is available to the potential-free contact c.a1/c.a2 (30 V DC / 2 A).
- ▶ The control board has various LEDs for the visual display.
- ▶ It also features a micro-fuse.

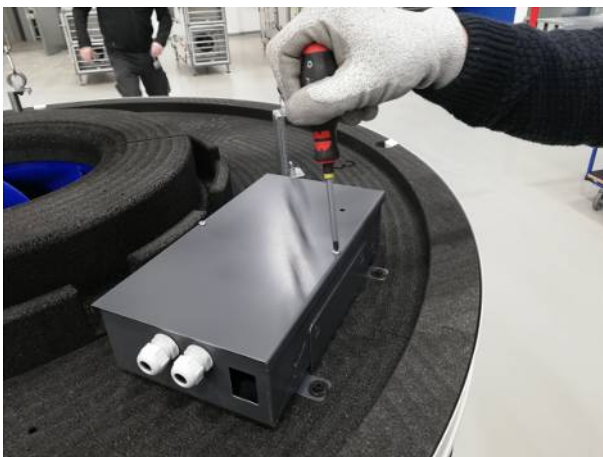

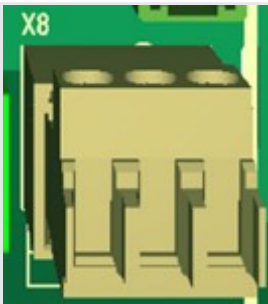

Fig. 10: Open the electrical box.



Fig. 11: Control board





1	230 V voltage	2	Optional: condensate pump power supply
3	Valve actuator, optional damper actuator and optional condensate alarm	4	Heating / cooling switch-over
5	0 - 10 V control and potential-free fault alarms (motor and condensate)	6	

## Description of the control board Rev. 1.06 (\*00)



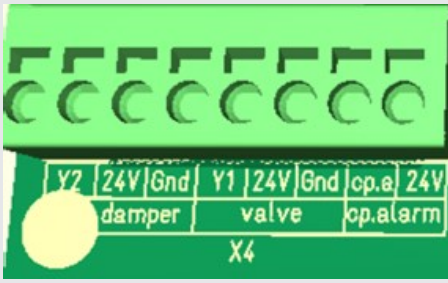

Section of the printed circuit board	Description
	<p>Terminal block X8 (230 V AC feed)</p> <ul style="list-style-type: none"> <li>▶ 230 V AC / 50 Hz feed</li> <li>▶ PE, N, L</li> </ul>
	<p>Terminal block X1 (230 V Y1 valve control)</p> <ul style="list-style-type: none"> <li>▶ External valve control Y1 230V AC / 50Hz Open/Closed for heating/cooling</li> <li>▶ For the control of a 24 V DC valve output (X4 valve)</li> </ul>

# Ultra Allround

Assembly, installation and operating instructions

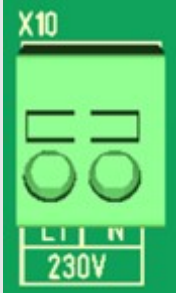
Section of the printed circuit board	Description
	<p><b>Terminal block X2 (control voltage / fault alarm):</b></p> <ul style="list-style-type: none"> <li>▶ UC/GND 0-10 V DC signal for EC fan speed continuously variable</li> <li>▶ A+/B- External modbus connection for EC fan</li> <li>▶ f.e1/f.e2 potential-free motor alarm contact 30 V DC / 2 A</li> <li>▶ No fault -&gt; contact closed</li> <li>▶ c.a1/c.a2 potential-free condensate alarm contact 30 V DC / 2 A</li> <li>▶ No fault -&gt; contact closed</li> </ul>
	<p><b>Terminal block X3 (damper switch-over control):</b></p> <ul style="list-style-type: none"> <li>▶ c/h–GND External contact for damper switch-over (heating / cooling switch-over // open = heating mode)</li> <li>▶ com/no (K4) – Potential-free output contact (heating / cooling) 30 V DC / 2 A</li> <li>▶ Y1 - External valve control Y1: 24 V DC Open / Closed for heating / cooling</li> <li>▶ Y2 – External damper control Y2: 24 V DC Open / Closed for air deflection</li> <li>▶ 24 V-GND – Output contact 24 V DC</li> </ul>
	<p><b>Terminal block X4 (valve / damper / condensate alarm connection):</b></p> <ul style="list-style-type: none"> <li>▶ (Valve) Valve actuator Y1 24 V DC Open / Closed</li> </ul> <p>2-pipe version: Heating/cooling valve</p> <ul style="list-style-type: none"> <li>▶ (Damper) Damper actuator Y2 24 V DC Open / Closed</li> </ul> <p>2-pipe version: Heating / cooling air deflection</p> <ul style="list-style-type: none"> <li>▶ (cp.alarm) Condensate pump alarm contact</li> <li>▶ Note: The valve (Y1) is actively closed in the event of a condensate alarm.</li> <li>▶ No condensate pump: jumper factory-inserted!</li> </ul>
	<p><b>Terminal block X5 (fan connection):</b></p> <ul style="list-style-type: none"> <li>▶ (UC/GND) 0-10 V signal</li> <li>▶ (B-/A+) Modbus signal</li> </ul>
	<p><b>Terminal block X6 (fan fault connection):</b></p> <ul style="list-style-type: none"> <li>▶ (Fan error) Fan alarm input</li> <li>▶ Decoupled via K1; potential-free output via X2</li> </ul> <p>fe1/fe2 ; 30 V DC / 2</p>

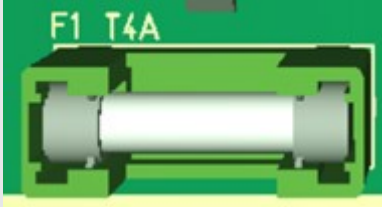

Section of the printed circuit board	Description
	<p><b>Terminal block X7 (fan / condensate pump power supply connection):</b></p> <ul style="list-style-type: none"> <li>▶ 230 V AC / 50 Hz</li> <li>▶ Fan and condensate pump</li> </ul>
	<p><b>Terminal block X10 (output voltage):</b></p> <ul style="list-style-type: none"> <li>▶ Output voltage 230 V AC / 50 Hz</li> </ul> <p>Possible indication:</p> <ul style="list-style-type: none"> <li>▶ Repair switch activated / deactivated</li> <li>▶ Fuse or electrical unit failure</li> </ul>
	<p><b>Visual display:</b></p> <ul style="list-style-type: none"> <li>▶ LED 1 (red) = condensate pump fault</li> </ul> <p>Cp = condensate pump / dpm = dew point measure / humidity</p> <ul style="list-style-type: none"> <li>▶ LED 2 (yellow) = cooling switch-over active</li> </ul>
	<p><b>Fuse F1:</b></p> <ul style="list-style-type: none"> <li>▶ Fuse 4 A slow-acting</li> <li>▶ 230 V AC</li> <li>▶ Dimensions: 5 x 20 mm</li> </ul>
	<p><b>Jumper J1 (fan speed limit with wet cooling)</b></p> <ul style="list-style-type: none"> <li>▶ Jumper inserted: fan speed reduction to approx. 7.5 V</li> <li>▶ No jumper: no fan speed reduction (10 V)</li> </ul>
	<p><b>Repair switch</b></p> <ul style="list-style-type: none"> <li>▶ A lockable repair switch is always fitted and connected to the electrical housing.</li> </ul>

### Informations sur la pose des câbles :

Les indications suivantes concernant les types de câbles et la pose des câbles doivent être respectées en tenant compte de la norme VDE 0100.

L'installation, l'utilisation et l'entretien de ces appareils doivent être conformes aux lois, normes, prescriptions et directives en vigueur dans le pays concerné.

Sans \* : NYM-J. Le nombre de conducteurs nécessaires, y compris le conducteur de protection, est indiqué sur le câble. Les sections ne sont pas indiquées, car la longueur du câble est prise en compte dans le calcul de la section.

\*) : Câble blindé, J-Y(ST)Y 0,8mm. Pose séparée des lignes à courant fort.

\*\*) : Câble blindé torsadé par paires, par exemple UNITRONIC® BUS LD 2x2x0,22, UNITRONIC® BUS LD 3x2x0,22. Poser séparément des lignes à courant fort.

- En cas d'utilisation d'autres types de câbles, ceux-ci doivent être au moins équivalents.

- Les bornes de raccordement sur l'appareil sont adaptées à une section de fil maximale de 2,5 mm<sup>2</sup>, la fiche secteur à une section de fil maximale de 4,0 mm<sup>2</sup>.

- En cas d'utilisation de disjoncteurs différentiels, ceux-ci doivent être au moins sensibles à la fréquence mixte (type F). Pour le dimensionnement du courant de défaut assigné, il convient de respecter les prescriptions de la norme DIN VDE 0100 parties 400 et 500.

- Pour la conception de l'alimentation secteur et de la protection par fusible (C16A, max. 10 appareils), les données électriques du tableau ci-dessous doivent être respectées.

- Les câbles pour les signaux de données ou de bus sont représentés avec le blindage raccordé d'un côté. Les câbles pour signaux analogiques sont représentés avec un blindage non raccordé. En raison des conditions de construction ou locales et selon le type et l'importance des influences perturbatrices, qui peuvent être causées entre autres par des champs magnétiques et/ou électriques dans des plagues de fréquences élevées et/ou basses, un raccordement différent du blindage (accordé des deux côtés ou non raccordé) peut s'avérer nécessaire. Ceci doit être vérifié par le client et, le cas échéant, être réalisé différemment des indications figurant dans la documentation !

### Électromécanique :

- Longueur de câble entre le régulateur de vitesse et le dernier appareil : 100 m maximum, à partir de 20 m, poser le blindage d'un côté.

- Longueur de câble entre le thermostat d'ambiance et la sonde de température ou le contact de commutation : 50 m maximum.

- Longueur de câble entre le régulateur de vitesse et la sonde de température ou le contact de commutation : 100 m maximum.

### KaControl :

- Longueur de câble de la sonde de température ou du contact de commutation : 30 m maximum (100 m maximum pour une section de fil minimale de 1,0 mm<sup>2</sup>).

- Longueur de la ligne BUS de la commande de pièce KaController vers l'appareil 1 : 30 m maximum.

- Nombre maximal d'appareils en parallèle : 6. Avec la carte CANbus de type 3260301 nécessaire pour chaque appareil (voir accessoires), 30 pièces maximum.

- Longueur du câble BUS de l'appareil 1 à l'appareil 6 : 30 m maximum. Avec la carte CANbus type 3260301 (voir accessoires) nécessaire pour chaque appareil, 500 m maximum.

Bearbeiter: Erstelldatum: 08.05.2023	Projekt: Projekt-Nr.:	Blatt-Nr.: 1 von 6	 Genau mein Klima.
	informations générales		

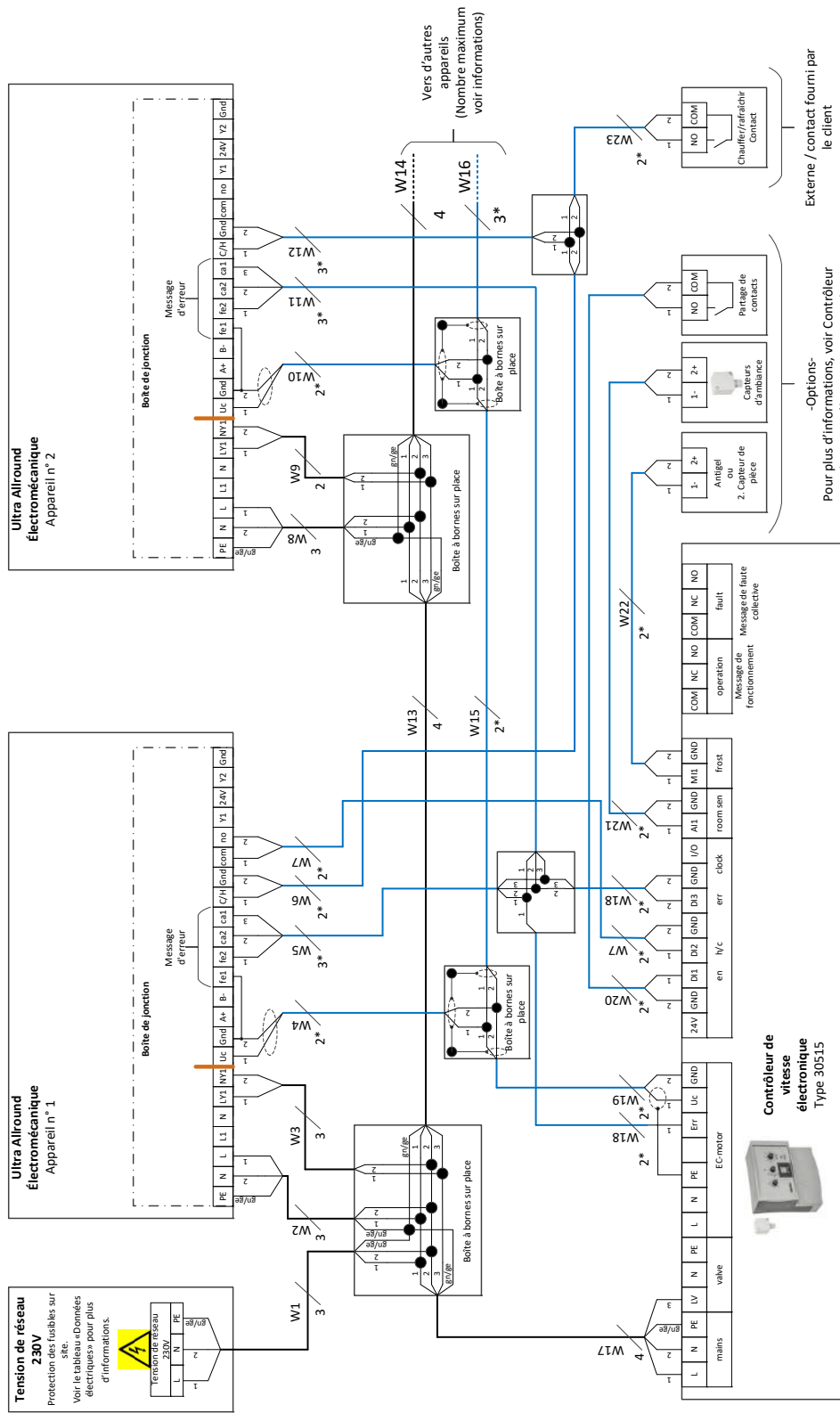

Bearbeiter:	Projekt:	Ultra Allround, électromécanique, Contrôleur de vitesse électronique Type 30515	Blatt-Nr.:	2 von 6
Erstelldatum: 08.05.2023	Projekt-Nr.:			

# Ultra Allround

Assembly, installation and operating instructions

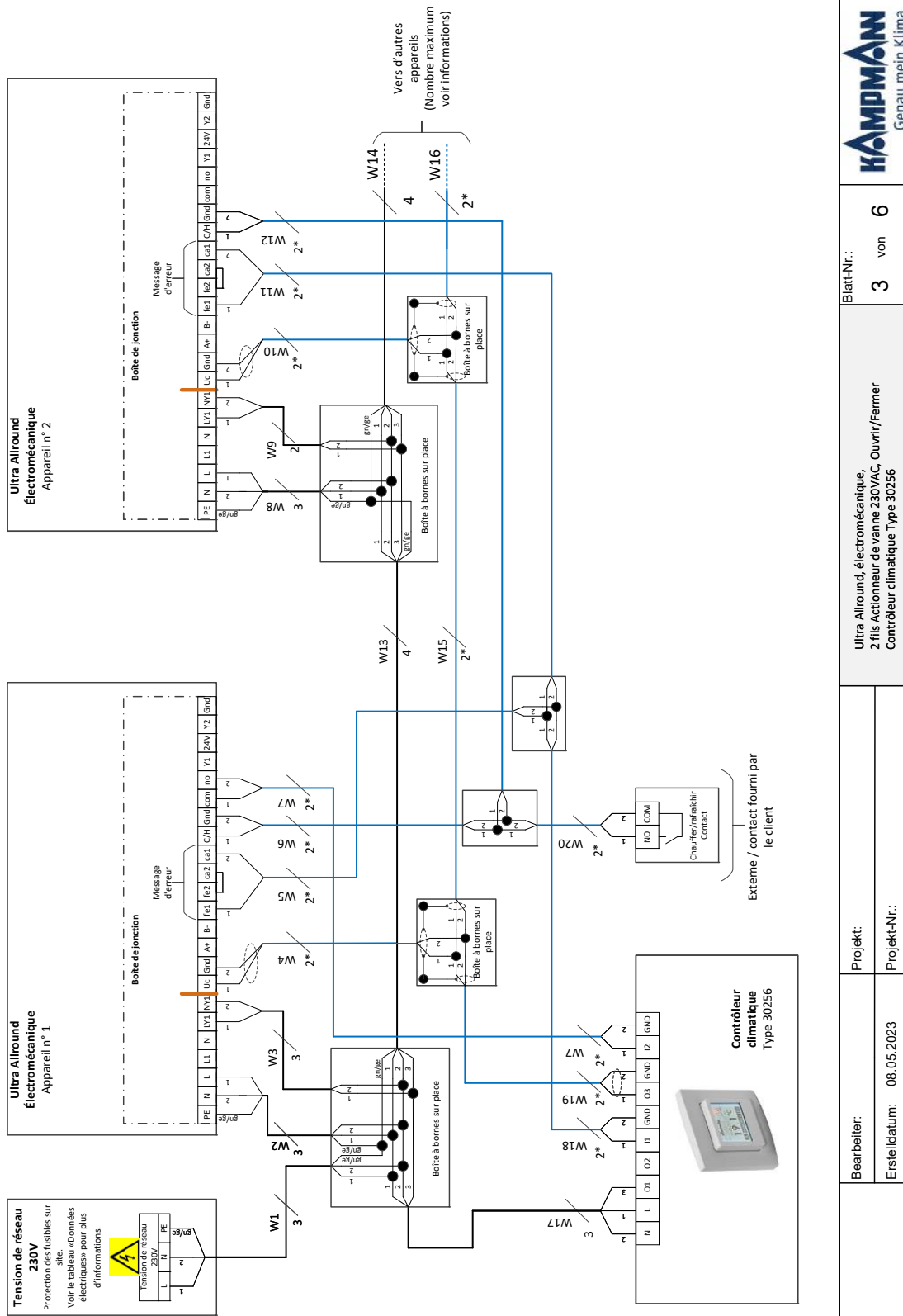



Bearbeiter: Erstelldatum: 08.05.2023	Projekt: Projekt-Nr.:	Blatt-Nr.: 3 von 6	 Genau mein Klima.
	Ultra Allround, électromécanique, 2 fils Actionneur de vanne 230VAC, Ouvrir/Fermer Contrôleur climatique Type 30256		

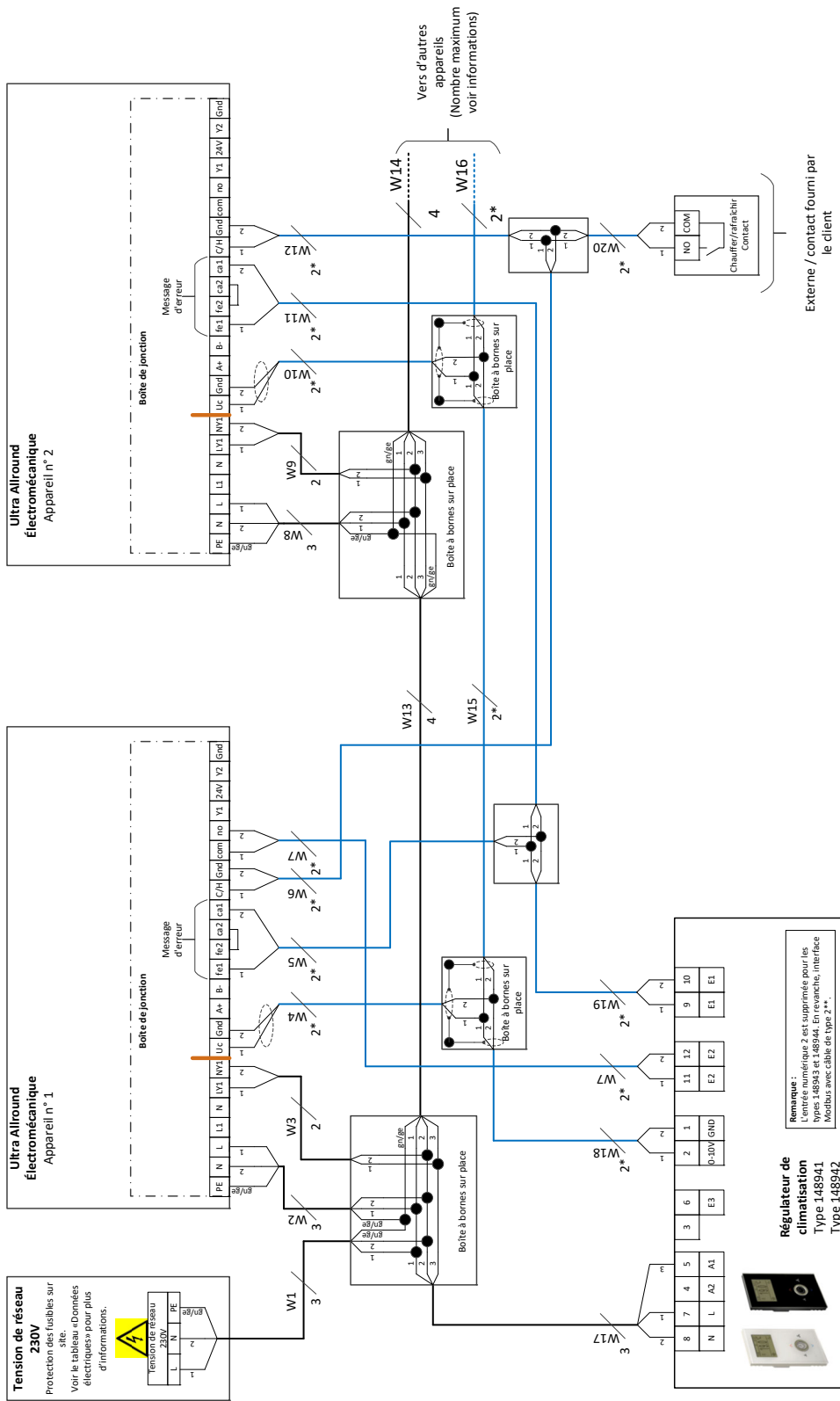

# Ultra Allround

Assembly, installation and operating instructions



Bearbeiter: Erstelldatum: 08.05.2023	Ultra Allround, électromécanique, Régulateur de climatisation Type 14894x		Blatt-Nr.: 5 von 6
	Projekt: Projekt-Nr.:	 Genau mein Klima.	

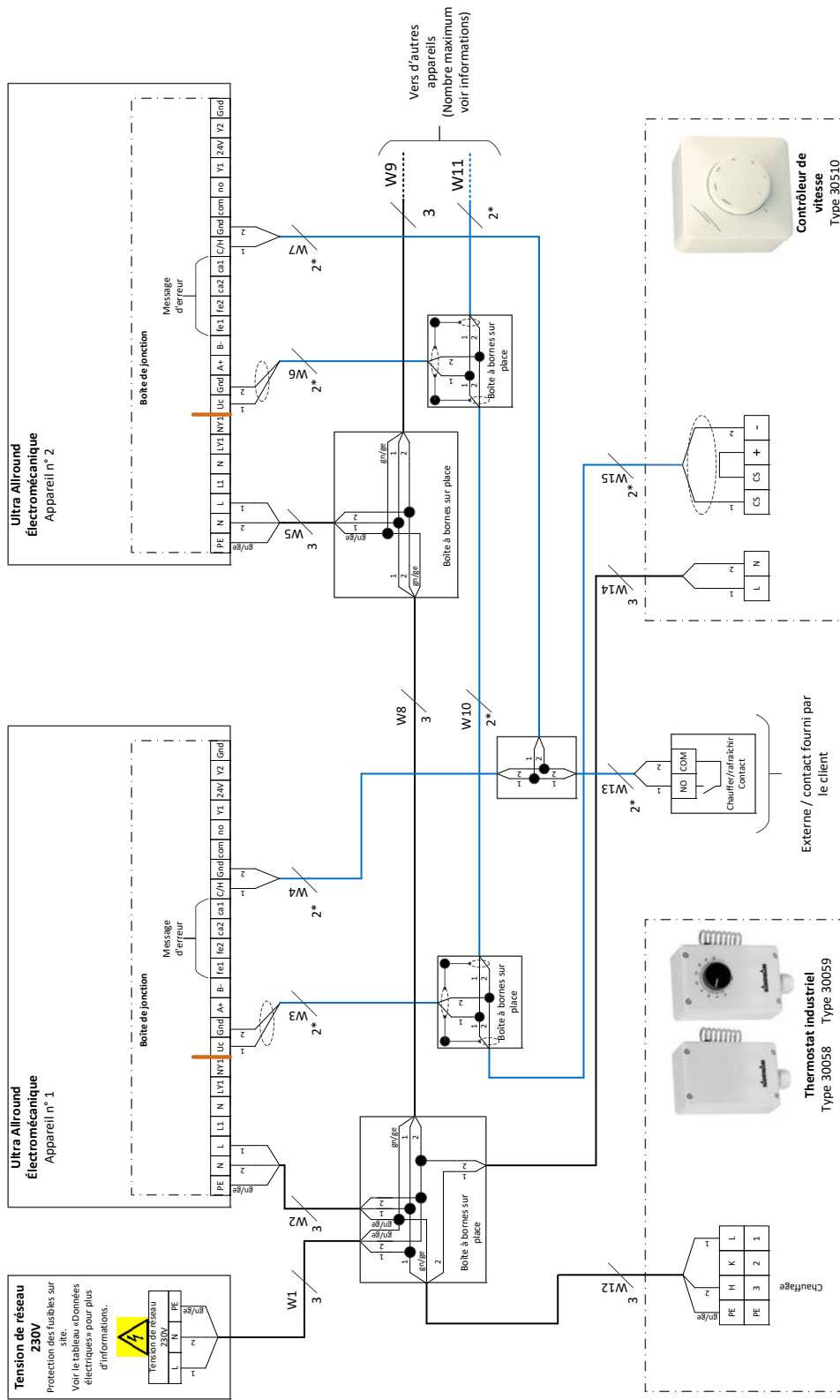

Bearbeiter:	Projekt:	Ultra Allround, électromécanique. Contrôleur de vitesse Type 30510 avec Thermostat industriel Type 30058/30059	Blatt-Nr.: 6 von 6
Erstelldatum: 08.05.2023	Projekt-Nr.:		<b>KAMPMANN</b> Genau mein Klima.

# Ultra Allround

Assembly, installation and operating instructions

## 7.3 KaControl (\*C1)

### 7.3.1 KaController installation

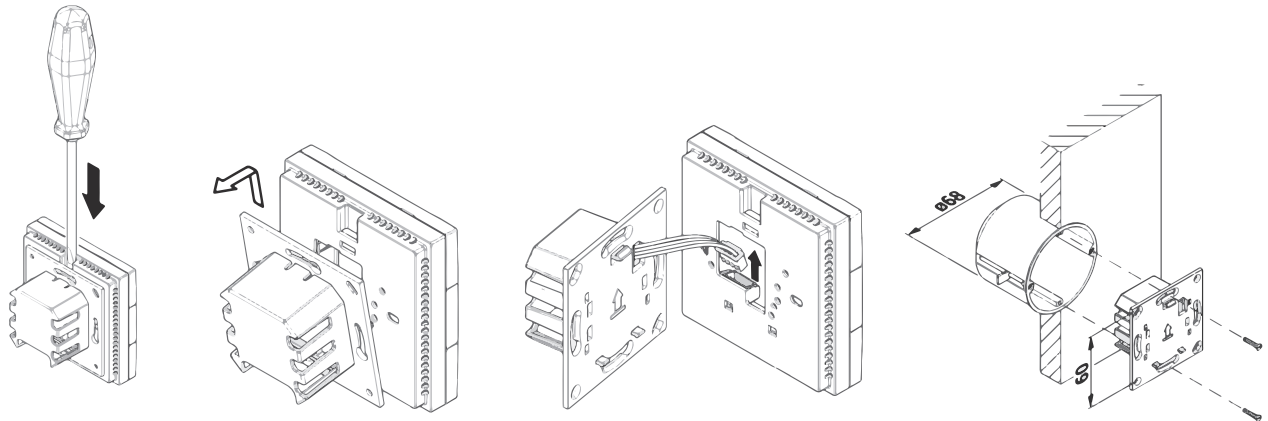

Fig. 12: Installation of flush-mounted back box

	<p><b>Electrical connection</b></p> <ul style="list-style-type: none"> <li>▶ Connect the KaController to the nearest KaControl unit in line with the wiring diagram. The maximum bus length between the KaController and the KaControl master unit is 30 m.</li> <li>▶ The respective KaControl automatically becomes the master unit in the control circuit when a KaController is connected to it.</li> </ul>
	<p><b>DIP switch setting</b></p> <p>The DIP switches on the rear of the KaController should be set according to the illustration:</p> <ul style="list-style-type: none"> <li>▶ DIP switch 1: ON</li> <li>▶ DIP switch 2: OFF</li> </ul>

Fig. 13: KaController terminals

Fig. 14: DIP switch setting on KaController



## 7.3.2 Connection (\*C1)

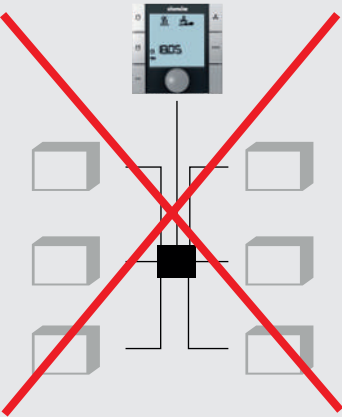

**Wrong!**  
Star-shaped wiring of the bus lines.

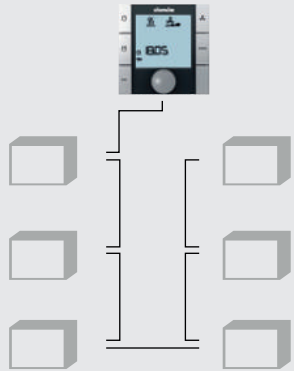

**Right!**  
Linear wiring of the bus lines.

**General information**

- ▶ Route all low voltage cables along the shortest route.
- ▶ Ensure that low-voltage and power cables are separated, using metal partitions on cable harnesses.
- ▶ Use only shielded cables as low-voltage and bus cables.
- ▶ Lay all BUS cables in a linear pattern. Star-shaped wiring is not permitted.
- ▶ The KaController is connected via a bus connection to the respective control PCB on the unit.

Tab. 6: Wiring of bus lines



### IMPORTANT NOTE!

Use shielded, paired cables as bus cables, UNITRONIC® BUS LD 2x2x0.22, but at least of the same value or higher.



### IMPORTANT NOTE!

When laying bus cables, avoid the formation of star points, for instance in junction boxes. Loop the cables through to the units!

# Ultra Allround

Assembly, installation and operating instructions

## Circuit description

- ▶ All units need a 230 V AC power supply.
- ▶ A lockable repair switch is always fitted and connected to the electrical housing.
- ▶ Factory-fitted actuators are wired to the terminals. The appropriate terminals are available for valve actuators.
- ▶ Only 24 V DC valve actuators Open/Closed can be connected.
- ▶ The speed of the EC fans is controlled by a 0-10 V DC signal from the KaControl. The "intelligent" motor electronics detects any possible motor malfunction and automatically switches off the fan.
- ▶ The cooling valve (Y1) is actively closed in the event of a condensate alarm.
- ▶ A motor malfunction signal is available to the potential-free contact f.e1/f.e2 (30 V DC / 2 A).
- ▶ A condensate alarm is available to the potential-free contact c.a1/c.a2 (30 V DC / 2 A).
- ▶ The control board has various LEDs for the visual display.
- ▶ It also features a micro-fuse.

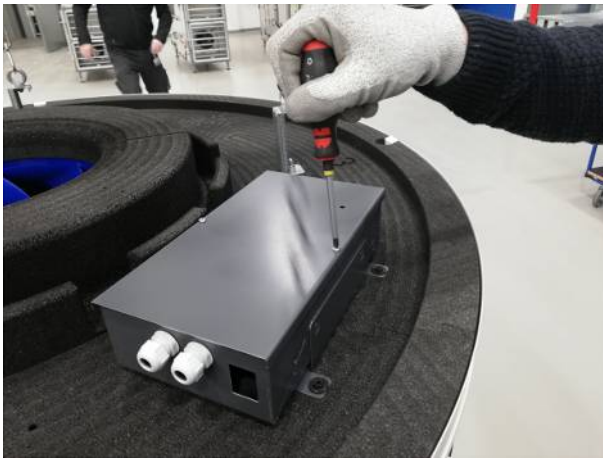

Fig. 15: Open the electrical box.

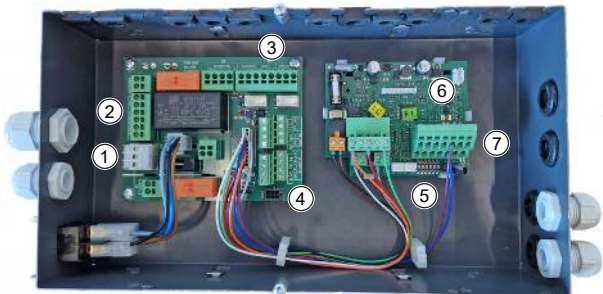
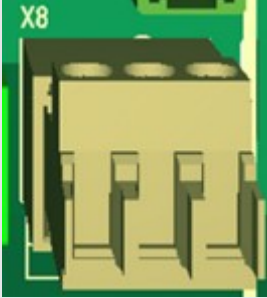

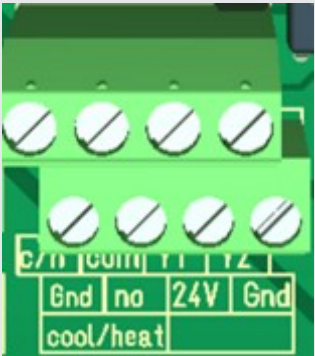



Fig. 16: Junction box





1	Power supply 230 V	2	Optional condensate pump power supply
3	Valve actuator, optional damper actuator and optional condensate alarm	4	Potential-free fault alarms (motor and condensate)
5	DIP switch	6	Slot for interface card
7	KaController connection and control contacts		

## Description of the control board Rev. 1.06 (\*C1)

Section of the printed circuit board	Description
 <p>X8</p>	<p>Terminal block X8 (230 V AC feed)</p> <ul style="list-style-type: none"> <li>▶ 230 V AC / 50 Hz feed</li> <li>▶ PE, N, L</li> </ul>
 <p>fan control</p>	<p>Terminal block X2 (control voltage / fault alarm):</p> <ul style="list-style-type: none"> <li>▶ f.e1/f.e2 potential-free motor alarm contact 30 V DC / 2 A</li> <li>▶ No fault -&gt; contact closed</li> <li>▶ c.a1/c.a2 potential-free condensate alarm contact 30 V DC / 2 A</li> <li>▶ No fault -&gt; contact closed</li> </ul>
 <p>cool/heat</p>	<p>Terminal block X3 (damper switch control):</p> <ul style="list-style-type: none"> <li>▶ com/no (K4) – Potential-free output contact (heating / cooling) 30 V DC / 2 A</li> <li>▶ 24 V-GND – Output contact 24 V V DC</li> </ul>
 <p>X4</p>	<p>Terminal block X4 (valve / damper / condensate alarm connection):</p> <ul style="list-style-type: none"> <li>▶ (Valve) Valve actuator Y1 24 V DC Open/Closed: 2-pipe version: Heating/cooling valve</li> <li>▶ (Damper) Damper actuator Y2 24 V DC Open / Closed: 2-pipe version: Heating / cooling air deflection</li> <li>▶ (cp.alarm) Condensate pump alarm contact</li> <li>▶ Note: The valve (Y1) is actively closed in the event of a condensate alarm.</li> <li>▶ No condensate pump: jumper factory-inserted!</li> </ul>
 <p>fan / condensat pump</p>	<p>Terminal block X7 (fan / condensate pump power supply connection):</p> <ul style="list-style-type: none"> <li>▶ 230 V / 50 Hz</li> <li>▶ Fan and condensate pump</li> </ul>

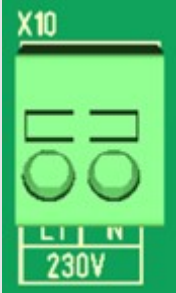
# Ultra Allround

Assembly, installation and operating instructions

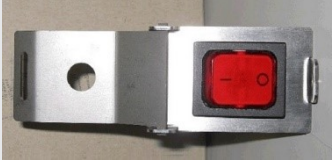
Section of the printed circuit board	Description
	<p><b>Terminal block X10 (output voltage):</b></p> <ul style="list-style-type: none"> <li>▶ Output voltage 230 V AC / 50 Hz</li> <li>▶ Possible indication:             <ul style="list-style-type: none"> <li>– Repair switch activated</li> <li>– Fuse or electrical unit failure</li> </ul> </li> </ul>
	<p><b>Visual display:</b></p> <ul style="list-style-type: none"> <li>▶ LED 1 (red) = condensate pump fault</li> </ul> <p>Cp = condensate pump/ dpm = dew point measure / humidity</p> <ul style="list-style-type: none"> <li>▶ LED 2 (yellow) = cooling switch-over active</li> </ul>
	<p><b>Fuse F1:</b></p> <ul style="list-style-type: none"> <li>▶ Fuse 4 A slow-acting</li> <li>▶ 230 V AC</li> <li>▶ Dimensions: 5 x 20 mm</li> </ul>
	<p><b>Jumper J1 (fan speed limit with wet cooling)</b></p> <ul style="list-style-type: none"> <li>▶ Jumper inserted: fan speed reduction to approx. 7.5 V</li> <li>▶ No jumper: no fan speed reduction (10 V)</li> </ul>
	<p><b>Repair switch</b></p> <ul style="list-style-type: none"> <li>▶ A lockable repair switch is always fitted and connected to the electrical housing.</li> </ul>

## Information on cable laying:

The following information on cable types and cable laying must be observed in compliance with VDE 0100.

The installation, operation and maintenance of these devices must comply with the country-specific applicable laws, standards, regulations and directives.

Without \*: NYM-J. The required number of cores incl. protective conductor is indicated on the cable. Cross sections are not indicated, as the cable length is included in the calculation of the cross section.

\*): Shielded cable, J-Y(STY) 0.8mm. Lay separately from power lines.

\*\*): Shielded cable stranded in pairs, e.g. UNITRONIC® BUS LD 2x2x0.22, UNITRONIC® BUS LD 3x2x0.22. Install separately from power lines.

- If other cable types are used, they must be at least equivalent.

- The connection terminals on the device are suitable for a maximum wire cross-section of 2.5 mm<sup>2</sup>, the mains plug for max. 4.0 mm<sup>2</sup>.

- When using residual current circuit breakers, these must be at least mixed frequency sensitive (type F). For the design of the rated residual current, the specifications from DIN VDE 0100 Parts 400 and 500 must be observed.

- For the design of the on-site mains supply and fuse protection (C16A, max. 10 devices), the electrical data in the table below must be observed.

- Lines for data or bus signals are shown with shield connected at one end. Lines for analog signals are shown with the shield not connected. Due to structural or local conditions and depending on the type and level of interference, which can be caused by magnetic and/or electric fields in high and/or low frequency ranges, among other things, a different connection of the shield (connected at both ends or not connected) may be necessary. This must be checked by the customer and, if necessary, carried out deviating from the specifications in the documentation!

## Electromechanical:

- Cable length between speed controller and the last device: maximum 100 m, from 20 m connect shield on one side.

- Cable length between room thermostat and temperature sensor or switch contact: maximum 50 m.

- Cable length between speed controller and temperature sensor or switching contact: maximum 100 m.

## KaControl:

- Cable length temperature sensor or switching contact: maximum 30m (maximum 100m with minimum wire cross-section of 1.0 mm<sup>2</sup>).

- Cable length BUS cable room control unit KaController to unit 1: maximum 30 m.

- Maximum number of devices in parallel: 6 pieces. With CANbus card type 3260301 (see accessories) required for each unit: maximum 30 units.

- BUS cable length from device 1 to device 6: maximum 30 m. With CANbus card type 3260301 (see accessories) required for each device, maximum 500 m.

<b>KaControl®</b>	Bearbeiter:	Projekt:	<b>General Information</b>	Blatt-Nr.:
	Erstelldatum: 08.05.2023	Projekt-Nr.:		2 von 6



# Ultra Allround

Assembly, installation and operating instructions

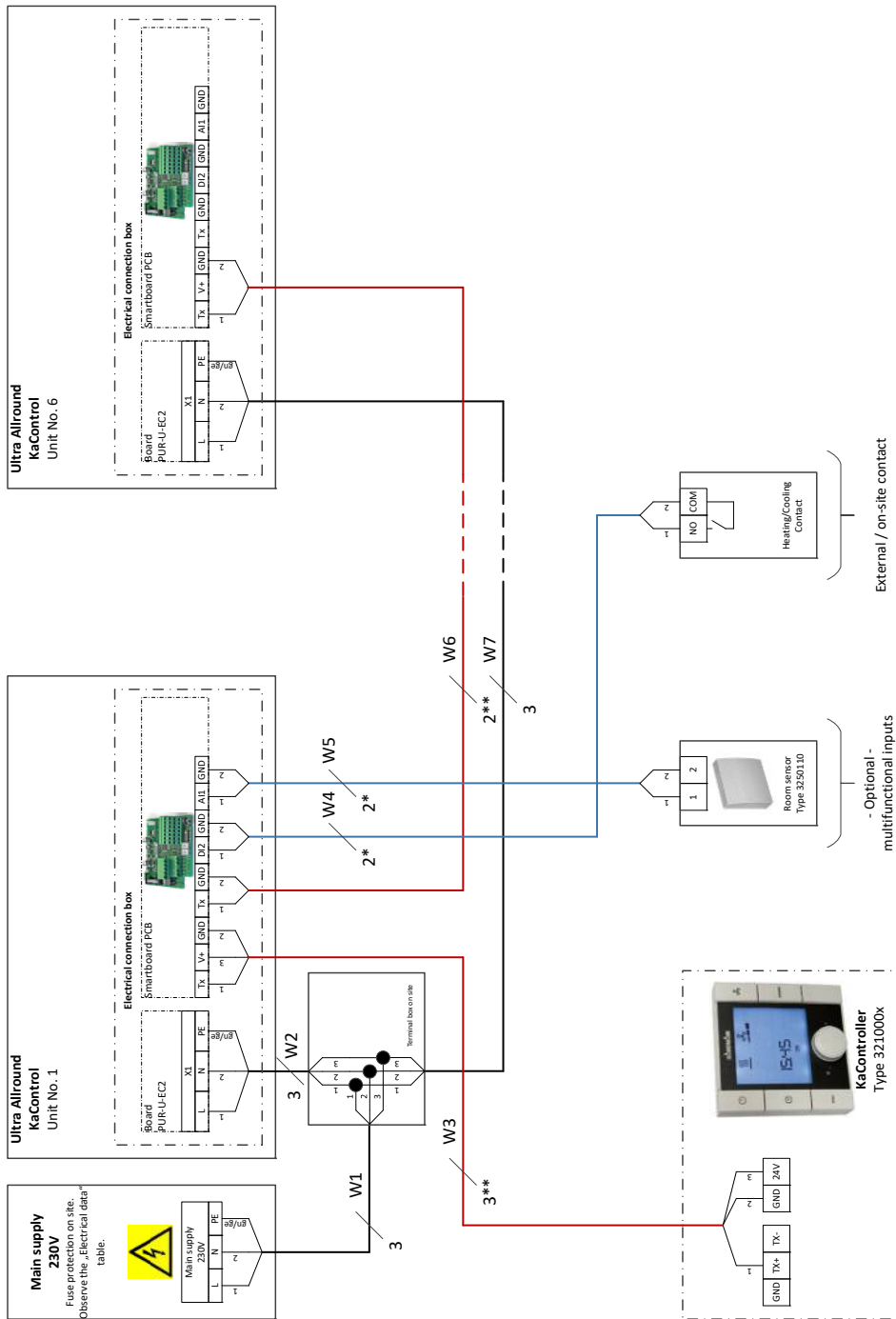

<b>KaControl®</b> Bearbeiter: Erstelldatum: 08.05.2023	Projekt: Projekt-Nr.:	Ultra Allround, KaControl, 6 units, 2-wire, valve 24VDC open/dlose, KaController Type 321000x	Blatt-Nr.: 2 von 4

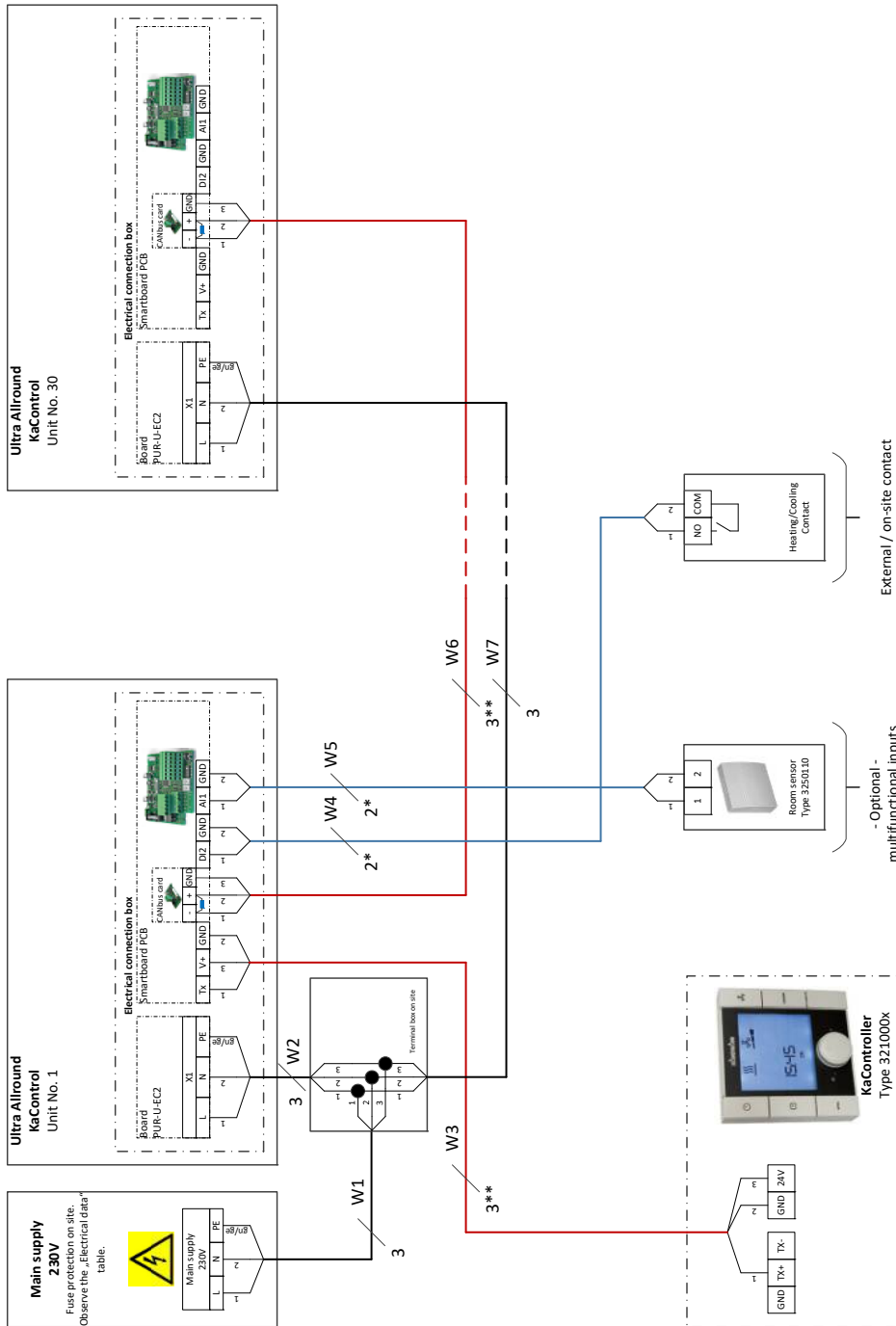

	Bearbeiter:	Projekt:	Blatt-Nr.:
	Erstelldatum: 08.05.2023	Projekt-Nr.:	1 von 4
Ultra Allround, KaControl, 30 units with CANBus card, 2-wire, valve 24VDC open/close, KaController Type 321000x			

# Ultra Allround

Assembly, installation and operating instructions

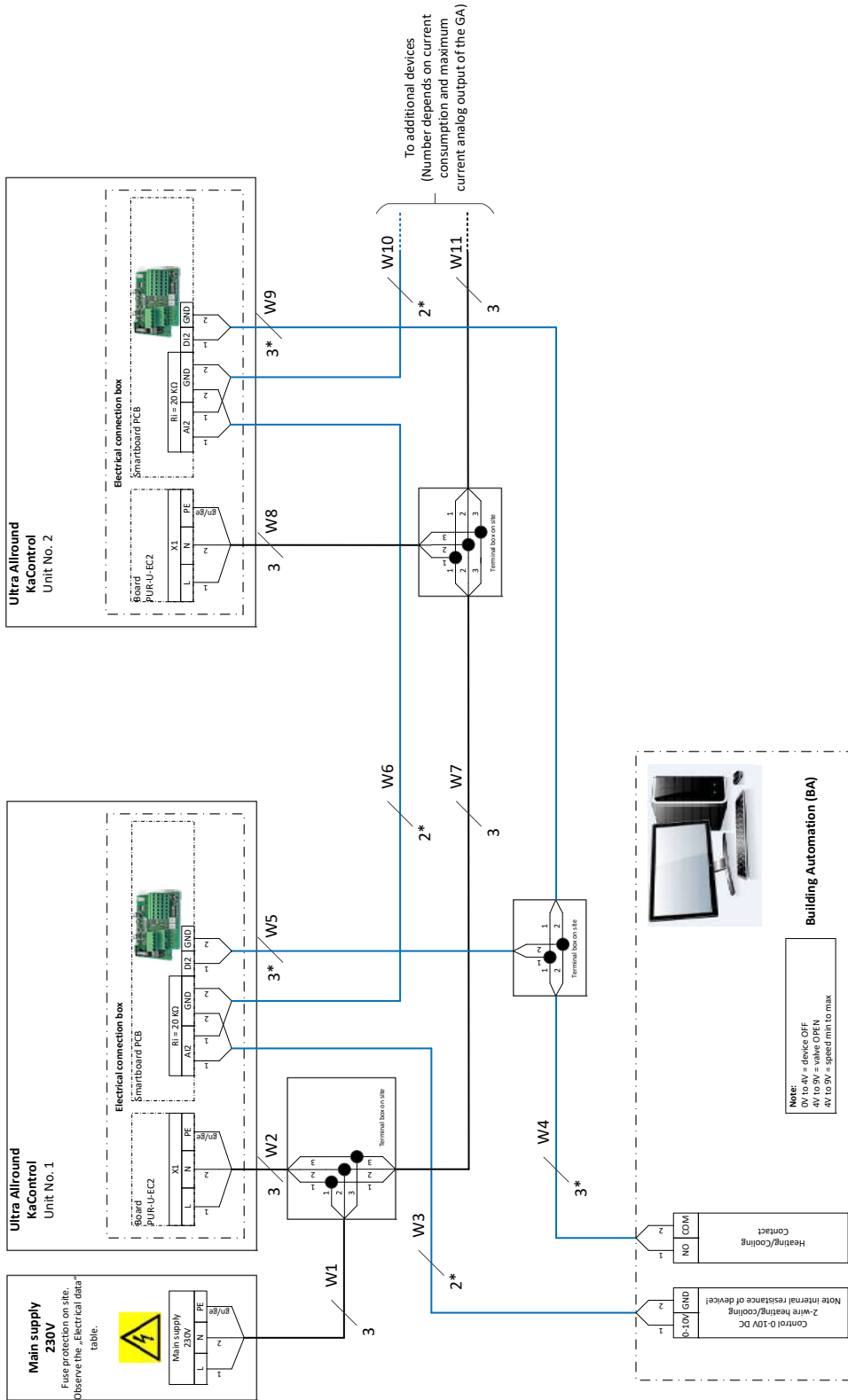

<b>KaControl®</b> Bearbeiter:	Projekt:	Ultra Allround, KaControl, 2-wire, valve 24VDC open/close, Control via an on-site 0-10VDC signal	Blatt-Nr.: 4 von 4
	Erstelldatum: 08.05.2023		





## 8 Pre-commissioning checks

During initial commissioning, it must be ensured that all necessary requirements are met so that the appliance can function safely and as intended.

### Structural tests

- ▶ Check that the unit is securely standing and fixed.
- ▶ Check the horizontal installation/suspension of the unit.
- ▶ Check whether all components are properly fitted.
- ▶ Check whether all dirt, such as packaging or site dirt, has been removed.

### Electrical tests

- ▶ Check whether all lines have been properly laid.
- ▶ Check whether all lines have the necessary cross-section.
- ▶ Are all wires connected in accordance with the electric wiring diagrams?
- ▶ Is the earth wire connected and wired throughout?
- ▶ Check all external electrical connections and terminal connections are fixed in place and tighten if necessary.

### Water-side checks

- ▶ Check whether all supply and drainage lines have been properly connected.
- ▶ Fill pipes and unit with water and bleed.
- ▶ Check whether all bleed screws are closed.
- ▶ Check leak tightness (pressure test and visual inspection).
- ▶ Check whether the parts carrying water have been flushed through.
- ▶ Check whether any shut-off valves fitted on site are open.
- ▶ Check whether any electrically actuated shut-off valves have been properly connected.
- ▶ Check whether all valves and actuators are working properly (note permitted mounting position).

### Air-side checks

- ▶ Check whether there is unimpeded flow at the air inlet and outlet.

### Condensation water connection

- ▶ Check whether the condensation tray is free of building rubble.
- ▶ Check the condensation drain and operation of the alarm signal on the condensation pump.
- ▶ Check whether the cooling valve switches off in the event of an alarm signal.
- ▶ Check whether the unit is connected leak-free to the on-site condensation connection.
- ▶ Check whether the waste water lines are clean and have a sufficient gradient.
- ▶ Check whether the condensation pump has a working power supply.

# Ultra Allround

Assembly, installation and operating instructions

## 9 Operation

### 9.1 Operation of electromechanical control



 <p>A white, square-shaped speed controller with a large rotary dial in the center. The dial has markings for 0, 25, 50, 75, and 100. There are also some indicator lights or symbols on the top left of the dial area.</p>	<p><b>Speed controller, type 30510</b></p> <p>The speed controller is used to activate the fan and pre-set the fan speed. Actuation of a thermoelectric shut-off valve is not possible.</p>
 <p>A rectangular electronic fan speed controller with a silver and black finish. It features a digital display, several control knobs, and a small sensor unit connected by a cable. The brand name 'KAMPMANN' is visible on the front panel.</p>	<p><b>Electronic fan speed controller, type 30515</b></p> <ul style="list-style-type: none"><li>▶ With integrated digital timer, IP class IP 40</li><li>▶ 230 V, EC, with day, night, week programme, continuously variable fan operation 0 to 100 %, manual or automatic, 0-10 VDC, recirculation air, including sensor</li><li>▶ Suitable for: EC units, electromechanical, max. number of connectible units: ten TIP, TOP, Resistent, Ultra or Venkon, two KaCool D AF or KaCool W</li></ul>
 <p>A white, rectangular room thermostat with a large rotary dial for temperature setting. It has a digital display and several control buttons, including 'MAN' and 'AUTO'. The brand name 'KAMPMANN' is visible on the bottom left.</p>	<p><b>Room thermostat, type 30155</b></p> <ul style="list-style-type: none"><li>▶ Electronic room thermostat with 3-stage automatic function for 2- and 4-pipe applications, surface-mounted wall installation on a flush-mounted box in visually unobtrusive design</li><li>▶ simple operation using a large rotary dial for temperature setting with mechanical range limitation of the temperature setpoint, operating mode selector switch, Standby, Manual fan, Automatic fan, 3-stage switch for pre-selecting the fan speed when the operating mode selector switch is in the "Manual fan" position</li><li>▶ option for external room sensor connection</li><li>▶ control input for heating/cooling changeover with 2-pipe applications</li><li>▶ digital input can be set to Comfort/ECO or ON/OFF switchover</li></ul>



Fig. 20: Clock thermostat type 30256

### Clock thermostat 230 V, type 30256

- ▶ Electronic clock thermostat for 2- and 4-pipe applications, surface-mounted wall installation on a flush-mounted box in visually unobtrusive design
- ▶ Operation using 4 sensor keys
- ▶ Timer with automatic summer/winter changeover
- ▶ Option for external room sensor
- ▶ Control input for heating/cooling changeover with 2-pipe applications
- ▶ Digital input can be set to Comfort/ECO or ON/OFF switchover
- ▶ Parallel operation of 2 units is possible



Fig. 21: Climate controller type 196000148941

### Climate controller, white, type 196000148941

- ▶ for 2- and 4-pipe applications, surface-mounted wall installation on a flush-mounted box with a visually unobtrusive design with 2.5" LCD display and high-quality glass finish with capacitive keys
- ▶ automatic LED backlight
- ▶ parametrisable language: German or English
- ▶ timer program with 3 time channels, each with 4 switch-over points
- ▶ option to connect an external room sensor
- ▶ 3 control inputs (functions parametrisable, e.g. window contact, presence detector, heating/cooling switchover)

# Ultra Allround

Assembly, installation and operating instructions



 <p>A black rectangular climate controller with a 2.5-inch LCD display showing 12:56, 19.0°C, and 31.0/17. Below the display are four capacitive touch keys: a red up arrow, a blue down arrow, a fan icon, and a power icon.</p>	<p><b>Climate controller, black, type 196000148942</b></p> <ul style="list-style-type: none"><li>▶ for 2- and 4-pipe applications, surface-mounted wall installation on a flush-mounted box with a visually unobtrusive design with 2.5" LCD display and high-quality glass finish with capacitive keys</li><li>▶ automatic LED backlight</li><li>▶ parametrisable language: German or English</li><li>▶ timer program with 3 time channels, each with 4 switch-over points</li><li>▶ option to connect an external room sensor</li><li>▶ 3 control inputs (functions parametrisable, e.g. window contact, presence detector, heating/cooling switchover)</li></ul>
 <p>A white rectangular climate controller with a 2.5-inch LCD display showing 12:56, 19.0°C, and 31.0/17. Below the display are four capacitive touch keys: a red up arrow, a blue down arrow, a fan icon, and a power icon.</p>	<p><b>Climate controller, white, type 196000148943</b></p> <ul style="list-style-type: none"><li>▶ with Modbus interface</li><li>▶ for 2- and 4-pipe applications, surface-mounted wall installation on a flush-mounted box with a visually unobtrusive design with 2.5" LCD display and high-quality glass finish with capacitive keys</li><li>▶ automatic LED backlight</li><li>▶ parametrisable language: German or English</li><li>▶ timer program with 3 time channels, each with 4 switch-over points</li><li>▶ Modbus-RTU interface as a slave device</li><li>▶ option to connect an external room sensor</li><li>▶ 2 control inputs (functions parametrisable, e.g. window contact, presence detector, heating/cooling switchover)</li></ul>

Fig. 22: Climate controller type 196000148942

Fig. 23: Climate controller type 196000148943



Fig. 24: Climate controller type 196000148944

## Climate controller, black, type 196000148944

- ▶ with Modbus interface
- ▶ for 2- and 4-pipe applications, surface-mounted wall installation on a flush-mounted box with a visually unobtrusive design with 2.5" LCD display and high-quality glass finish with capacitive keys
- ▶ automatic LED backlight
- ▶ parametrisable language: German or English
- ▶ timer program with 3 time channels, each with 4 switch-over points
- ▶ Modbus-RTU interface as a slave device
- ▶ option to connect an external room sensor
- ▶ 2 control inputs (functions parametrisable, e.g. window contact, presence detector, heating/cooling switchover)

# Ultra Allround

Assembly, installation and operating instructions

## 9.2 Operation of the KaController

The following information is limited to the key content on the operation of the KaController and KaControl system. More information is included separately in the KaControl SmartBoard user manual.

### 9.2.1 Function keys, display elements

All menus can be selected and set using the navigator dial.

The LED background lighting is automatically switched off 5 seconds after the KaController is last used. The LED background lighting can be permanently disabled using a parameter setting.

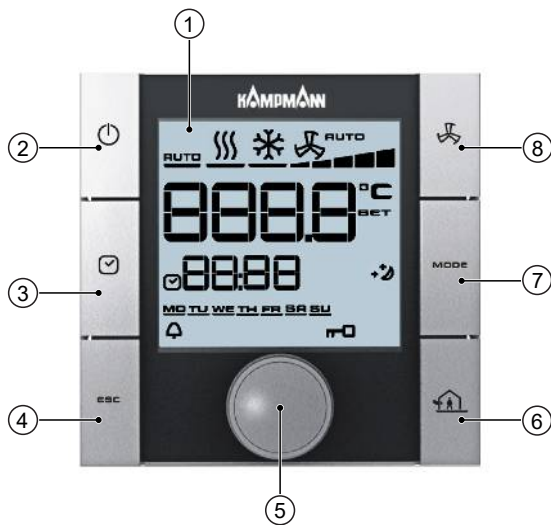



Fig. 25: KaController with function keys, type 3210002

1	Display with LED background lighting	2	ON/OFF key (depending on setting) ▶ ON/OFF ▶ Eco mode/Day mode (factory setting)
3	TIMER button ▶ Set time ▶ Set timer programs	4	ESC button ▶ back to standard view
5	Navigator dial ▶ Change settings ▶ Call up menus	6	House symbol ▶ External ventilation
7	MODE button ▶ Set operating modes (disabled with 2-pipe applications)	8	FAN button ▶ Set fan control

 <p>Fig. 26: KaController type 3210001</p>	<p>KaController without operating keys (one-button operation) type 3210001</p> <ol style="list-style-type: none"> <li>1. Display with LED background lighting</li> <li>2. Navigator dial             <ul style="list-style-type: none"> <li>▶ Change settings</li> <li>▶ Call up menus</li> </ul> </li> </ol>
 <p>Fig. 27: KaController black, type 3210006</p>	<p>KaController, black without function keys (one-button operation) type 3210006</p> <ol style="list-style-type: none"> <li>1. Display with LED background lighting</li> <li>2. Navigator dial             <ul style="list-style-type: none"> <li>▶ Change settings</li> <li>▶ Call up menus</li> </ul> </li> </ol>

The symbols shown on the display depend on the application (2-pipe, 4-pipe etc.) and the parameters set.

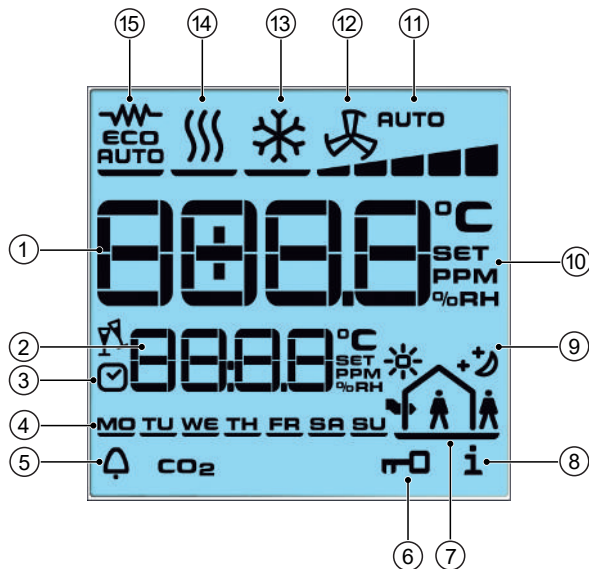

Fig. 28: Display

1	Display of setpoint room temperature	2	Current time
3	Timer program enabled	4	Weekday
5	Alarm	6	Selected function is locked
7	"External ventilation" mode is locked	8	Filter alert
9	Eco mode	10	Setpoint setting enabled
11	Fan control setting Auto-0-1-2-3-4-5	12	Ventilation mode
13	Cooling mode	14	Heating mode
15	Automatic Heating/Cooling changeover mode		

# Ultra Allround

Assembly, installation and operating instructions

## 10 Maintenance

### 10.1 Securing against reconnection



#### **DANGER!**

#### **Risk of death by unauthorised or uncontrolled restart!**

Unauthorised or uncontrolled restarting of the equipment can result in serious injury or death.

- ▶ Before restarting, ensure that all safety devices are fitted and working properly and that there is no hazard to humans.

Always follow the procedure described below to prevent accidental restart:

1. de-energise.
2. Prevent accidental re-connection.
3. Check that the equipment is de-energised.
4. Cover and cordon off adjacent live parts.



#### **WARNING!**

#### **Risk of injury from rotating parts!**

The fan impeller can cause severe injuries.

- ▶ Switch off the unit and prevent it from reconnection before commencing any work on moving components of the fan. Wait until all parts have come to a standstill.

### 10.2 Maintenance Schedule:

The sections below describe maintenance work needed for the proper and trouble-free operation of the equipment.

If there are signs of increased wear during regular checks, shorten the required maintenance intervals to the actual wear and tear. Contact the manufacturer with any questions about maintenance work and intervals.

Interval	Maintenance work
If necessary	Regular visual inspections and acoustic tests for damage, soiling and function.
External filter (with cooling): quarterly External air filter (heating only): every six months Secondary air filter: annually	Check filter for dirt, clean and change filter if necessary.
Humid cooling: every six months Dry cooling: annually	Check and clean appliance components (heat exchanger, condensate tray, condensate pump, condensate drain, float switch).
every six months	Check water-side connections, valves and screw connections for dirt, leaks and function.
annually	Check electrical connections.
annually	Clean air-conducting components/surfaces.
annually	Check dew point sensor for soiling and function. Replace sensor if necessary.



## 10.3 Maintenance work

### 10.3.1 Visual checks

#### **Clean the heat exchanger.**

Check the heat exchanger for soiling and carefully vacuum if necessary. Avoid damage to the pipework and fins.

### 10.3.2 Clean the inside of the unit

Check all elements that come into contact with air (internal surfaces of the unit, outlet elements etc.) for dirt or deposits during maintenance and use a commercially available product to remove.



#### **DANGER!**

#### **Risk of injury from burning**

High temperatures are produced at the fan's electronic housing. Avoid direct contact!



#### **IMPORTANT NOTE!**

#### **Do not use aggressive cleaning agents!**

Aggressive cleaning agents that can damage the paintwork must not be used on the fan. Water is not permitted to enter the inside of the motor or the electronics (through direct contact with seals or motor openings, for example), respect the protection rating (IP). Check the condensate drain holes (if present), positioned to suit the installation situation, for clearance. Run the fan for at least 1 hour at 80 to 100% of maximum speed before cleaning to prevent moisture accumulating in the motor! Run the fan for a minimum of 2 hours at 80 to 100% of maximum speed after the cleaning process!

# Ultra Allround

Assembly, installation and operating instructions

## 10.3.3 Dismantling the housing cover



Fig. 29: Removing the housing cover

- ▶ Turn the housing cover anti-clockwise and remove.



Fig. 30: Base plate safety cables

- ▶ Remove the safety cables from the base plate.
- ▶ Put the cover aside and refit once revision work has been completed.

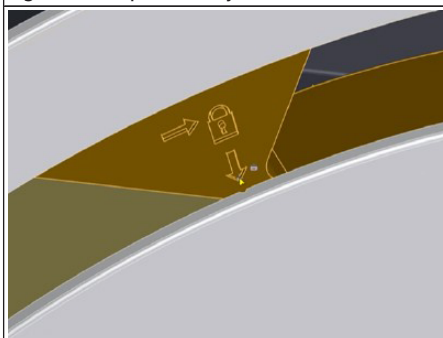

Fig. 31: Fitting the cover

- ▶ Once all maintenance work has been completed, when fitting the cover make sure that the lock shown lines up with one of the four notches.

## 10.3.4 Cleaning the condensate tray

With the Ultra cooling model, the condensate tray also needs to be dismantled after the housing cover to provide access to the unit for visual checks and any cleaning work needed.

**Note:** There could still be residual condensate in the condensate tray!



Fig. 32: Loosening the plug-in nuts

- ▶ Loosen the M6 plug-in nuts.
- ▶ Remove the condensate tray.



Fig. 33: Condensate tray (dismantled)

- ▶ Remove any dirt in the condensate tray. Clean the condensate lines as well if there is serious dirt in the condensate!

# Ultra Allround

Assembly, installation and operating instructions

## 10.3.5 Cleaning the condensate pump



Fig. 34: Inspection opening cover

- ▶ Remove the inspection opening cover to access the condensate pump.



Fig. 35: Loosening the cable

- ▶ Loosen the cable connections to the condensate pump.
- ▶ Remove and clean the condensate pump.



Fig. 36: Cleaning the pump sump

- ▶ When the condensate pump is removed, the pump sump of the condensate tray is freely accessible; give the pump sump a wipe and clean it.

### Condensate pump check

Once you have refitted the cleaned condensate pump, reinsert the condensate tray and fill it with water until the filling level monitor is half-filled with water. If it is working properly, the condensate pump should now start operating and drain the water.

## 10.3.6 Replacing the filter.



### CAUTION!

**Risk of injury from sharp metal housing!**

The inner metal of the casing can have sharp edges.

- ▶ Wear suitable protective gloves.

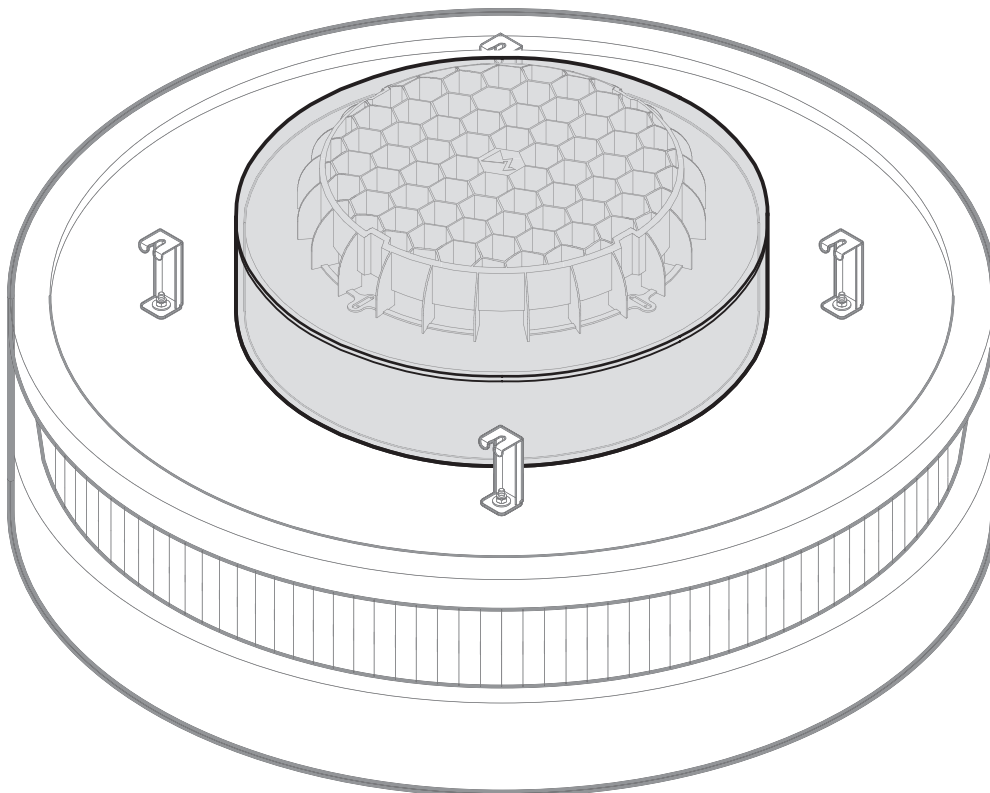

Fig. 37: Filter top

- ▶ Put on a new filter mat (see also Fitting the filter attachment (optional accessory) [▶ 21]).

# Ultra Allround

Assembly, installation and operating instructions

## 11 Faults

The following chapter describes possible causes of faults and the work needed to rectify them. Should faults occur frequently, shorten the maintenance intervals in line with the actual loading on the unit.

Contact the manufacturer with any faults that cannot be rectified using the following information.

### Behaviour in the event of faults

The following applies:

1. Immediately switch off the unit with faults that pose an immediate danger to persons or property!
2. Determine the cause of the fault!
3. Switch off the unit and prevent it from being reconnected if rectifying the fault requires work in the hazard area. Immediately advise a supervisor on site about the fault.
4. Either rectify the fault yourself or have it repaired by authorised personnel, depending on the nature of the fault.

The Fault table [► 58] provides information on who is authorised to rectify and remedy faults.

### 11.1 Fault table

Fault	Possible cause	Remedy
No function.	No power supply.	Check voltage, switch on repair switch.
		Replace fuse.
Unit too loud	Fan speed too high.	Set a lower fan speed, if possible.
	Air intake / air discharge opening is obstructed.	Free air routes.
	Filter dirty.	Replace filter.
	Rotating parts unbalanced	Clean and/or replace impeller. Make sure that no balancing brackets are removed during cleaning.
	Fan dirty.	Clean dirt from fan.
	dirty.	Clean dirt from the .

## 11.2 KaControl faults

Code	Alarms	Priority
A11	Faulty control sensor.	1
A12	Motor fault.	2
A13	Room frost protection.	3
A14	Condensation alarm.	4
A15	General alarm.	5
A16	Sensor AI1, AI2 or AI3 faulty.	6
A17	Unit frost protection.	7
A18	EEPROM error.	8
A19	Offline slave in the CAN bus network.	9

Tab. 7: KaControl unit alarms

Code	Alarms
tAL1	Temperature sensor in the KaController faulty.
tAL3	Real-time clock in the KaController faulty.
tAL4	EEPROM in the KaController faulty.
Cn	Communication fault with the external control.

Tab. 8: KaController alarms

## 11.3 Start-up after rectification of fault

After correction of the fault, carry out the following steps for recommissioning:

1. Make sure that all maintenance covers and access openings are sealed.
2. Switch off the unit.
3. Acknowledge the fault on the controller, if necessary.

# Ultra Allround

Assembly, installation and operating instructions

## 12 List of KaControl parameters

### 12.1 KaController parameter list

Parameter	Function	Standard	Min.	Max.	Unit	Comment
t001	Serial address	1	0	207	-	Address in Modbus network
t002	Baud rate 0 = Baud rate 4800 1 = Baud rate 9600 2 = Baud rate 19200	2	0	2	-	
t003	Background lighting function 0 = Slow fade in, fast fade out 1 = Slow fade in, slow fade out 2 = Fast fade in, fast fade out	0	0	2	-	
t004	Strong background lighting	4	0	5	-	
t005	Sensor calibration of KaController sensor	0	60	60	°C	
t006	LCD display contrast	15	0	15	-	
t007	BEEP setting 0 = BEEP ON 1 = BEEP OFF	0	0	1	-	
t008	Password for KaController Parameter menu	11	0	999	-	
t009	Minimum settable setpoint temperature	8	0	20	°C	
t010	Maximum settable setpoint temperature	35	10	40	°C	
t011	Interval of setpoint setting 0 = Automatic setting depending on PCB (parameterisable, freely programmable) 1 = Increment of 1 °C (parameterisable PCBs) 2 = Increment of 0.5 °C (freely programmable PCBs)	0	0	2	-	
t012	Date/Time setting: Year	9	0	99	-	
t013	Date/Time setting: Month	1	1	12	-	
t014	Date/Time setting: Day	1	1	31	-	
t015	Date/Time setting: Weekday	1	1	7	-	
t016	Date/Time setting: Hour	0	0	23	-	
t017	Date/Time setting: Minute	0	0	59	-	



## 13 Certificates



## EU-Konformitätserklärung

EU Declaration of Conformity  
Déclaration de Conformité CE  
Deklaracja zgodności CE  
EU prohlášení o konformite

### Wir (Name des Anbieters, Anschrift):

We (Supplier's Name, Address):  
Nous (Nom du Fournisseur, Adresse):  
My (Nazwa Dostawcy, adres):  
My (Jméno dodavatele, adresa):

**KAMPMANN** GMBH & Co. KG  
Friedrich-Ebert-Str. 128-130  
49811 Lingen (Ems)

### erklären in alleiniger Verantwortung, dass das Produkt:

declare under sole responsibility, that the product:  
déclarons sous notre seule responsabilité, que le produit:  
deklarujemy z pełną odpowiedzialnością, że produkt:  
deklarujeme, vědomi si své odpovědnosti, že produkt:

<b>Type, Modell, Artikel-Nr.:</b>	<b>TOP/TOP C</b>	<b>44****; 45****; 46****; 47****; 48****</b>
Type, Model, Articles No.:	<b>TIP</b>	<b>54****; 55****; 56****</b>
Type, Modèle, N° d'article:	<b>Resistent</b>	<b>84****; 85****; 86****</b>
Typ, Model, Nr artykułu:	<b>Ultra</b>	<b>73****; 84****; 85****; 96****; 97****</b>
Typ, Model, Číslo výrobku:	<b>Ultra Allround</b>	<b>3540*</b>
	<b>Bauheizer</b>	<b>54****; 55****; 56****</b>

### auf das sich diese Erklärung bezieht, mit der / den folgenden Norm(en) oder normativen Dokumenten übereinstimmt:

to which this declaration relates is in conformity with the following standard(s) or other normative document(s):  
auquel se réfère cette déclaration est conforme à la (aux) norme(s) ou autre(s) document(s) normatif(s):  
do którego odnosi się niniejsza deklaracja, jest zgodny z następującymi normami lub innymi dokumentami normatywnymi:  
na který se tato deklarace vztahuje, souhlasí s následující(mi) normou/normami nebo s normativními dokumenty:

<b>DIN EN 55014-1; -2</b>	<b>Elektromagnetische Verträglichkeit</b>
<b>DIN EN 61000-3-2; -3-3</b>	<b>Elektromagnetische Verträglichkeit</b>
<b>DIN EN 61000-6-1; -6-2; -6-3</b>	<b>Elektromagnetische Verträglichkeit</b>
<b>DIN EN 60335-1; -2-40</b>	<b>Sicherheit elektr. Geräte f. den Hausgebrauch und ähnliche Zwecke</b>

# Ultra Allround

Assembly, installation and operating instructions



## Gemäß den Bestimmungen der Richtlinien:

Following the provisions of Directive:  
Conformément aux dispositions de Directive:  
Zgodnie z postanowieniami Dyrektywy:  
Odpovídající ustanovení směrníc:

2014/30/EU	<b>EMV-Richtlinie</b>
2014/35/EU	<b>Niederspannungsrichtlinie</b>
2009/125/EG	<b>ErP-Richtlinie</b>
2016/2281 EU	<b>Durchführungsverordnung für Luftheizungsprodukte, Kühlungsprodukte, Prozesskühler mit hoher Betriebstemperatur und Gebläsekonvektoren</b>

**Frank Bolkenius**

## Lingen (Ems), den 06.03.2023

### **Ort und Datum der Ausstellung**

Place and Date of Issue  
Lieu et date d'établissement  
Miejsce i data wystawienia  
Místo a datum vystavení

### **Name und Unterschrift des Befugten**

Name and Signature of authorized person  
Nom et signature de la personne autorisée  
Nazwisko i podpis osoby upoważnionej  
Jméno a podpis oprávněné osoby

**Information requirements for fan coils according to regulation (EU) No 2016/2281**  
 Informationsanforderungen für Fan Coils gemäß Verordnung (EU) Nr. 2016/2281

Ultra Allround heating and cooling Heizen und Kühlen 2-pipe unit 2-Rohrsystem		cooling capacity (sensible)	Kühlleistung (sensibel)	cooling capacity (latent)	Kühlleistung (latent)	Heating capacity	Wärmeleistung	Total electric power input	Elektrische Gesamtleistungsaufnahme	Sound power level (per speed setting, if applicable)	Schalleistungspegel (ggf. je Geschwindigkeits-einstellung)
Model size Baugröße	Fan Ventilator	$P_{rated,c}$ kW	$P_{rated,c}$ kW	$P_{rated,h}$ kW	$P_{elec}$ kW	$L_{WA}$ dB (A)					
1	EC	13,0	4,3	17,5	0,266	27/44/56/64/70					
2	EC	16,0	5,4	21,8	0,268	27/45/57/66/73					

Standard rating conditions for fan coil units according to regulation (EU) No 2016/2281						
Norm-Prüfbedingungen für Gebläsekonvektoren gemäß Verordnung (EU) Nr. 2016/2281						
Cooling Test	Air temperature	27 °C (dry bulb) 19 °C (wet bulb)	Inlet water temperature	7 °C	Water temperature rise	5 °C
Test Kühlbetrieb	Lufttemperatur	27 °C (Trockenkugel) 19 °C (Feuchtkugel)	Wassertemperatur am Einlass		Anstieg der Wassertemperatur	
Heating Test	Air temperature	20 °C (dry bulb)	Inlet water temperature	45 °C for 2-pipe units 65 °C for 4-pipe units	Water temperature decrease	5 °C for 2-pipe units 10 °C for 4-pipe units
Test Heizbetrieb	Lufttemperatur	20 °C (Trockenkugel)	Wassertemperatur am Einlass	45 °C für 2-Rohrsysteme 65 °C für 4-Rohrsysteme	Sinken der Wassertemperatur	5 °C für 2-Rohrsysteme 10 °C für 4-Rohrsysteme
Sound power test	At ambient conditions without water flow					
Test Schalleistungspegel	Bei Umgebungsbedingungen ohne Wasserdurchsatz					
Contact Details	Kampmann GmbH & Co. KG					
Kontaktinformationen	Friedrich-Ebert-Straße 128-130, D-49811 Lingen (Ems), Germany					

# Ultra Allround

Assembly, installation and operating instructions

## Table

Tab. 1	Limits of operation .....	7
Tab. 2	Operating voltage .....	7
Tab. 3	Water quality.....	7
Tab. 4	Technical specifications .....	13
Tab. 5	Electrical specifications Ultra.....	26
Tab. 6	Wiring of bus lines .....	37
Tab. 7	KaControl unit alarms .....	59
Tab. 8	KaController alarms .....	59







<https://l.kampmanngroup.com/montage-ultra-allround>

Land	Kontakt
Germany	Kampmann GmbH & Co. KG
	Friedrich-Ebert-Str. 128 - 130
	49811 Lingen (Ems)
	T +49 591/ 7108-660
	F +49 591/ 7108-173
	E <a href="mailto:export@kampmann.de">export@kampmann.de</a>
	W <a href="http://Kampmann.eu">Kampmann.eu</a>

Country	Contact
Great Britain	Kampmann UK Ltd.
	Dial House, Govett Avenue
	Shepperton, Middlesex, TW17 8AG
	T +44 1932/ 228592
	F +44 1932/ 228949
	E <a href="mailto:info@kampmann.co.uk">info@kampmann.co.uk</a>
	W <a href="http://Kampmann.co.uk">Kampmann.co.uk</a>